

CHAMBERLAIN®

LiftMaster®
PROFESSIONAL

The Chamberlain Group, Inc.
845 Larch Avenue
Elmhurst, Illinois 60126-1196
www.liftmaster.com



*Radio
Receiver
Included*



Mega ARM Tower

Models:

MADCBB, MATDCBB, MASDCBB & MASTDCBB

(MEGA ARM, MEGA ARM TOWER, MEGA SPRINT & MEGA SPRINT TOWER)

1/2 HP COMMERCIAL DUTY PARKING GATE OPERATOR

INSTALLATION AND SERVICE MANUAL

IMPORTANT: Read and understand Warranty Page first.
Batteries (included) **MUST** be connected for proper operation of unit.
Use (2) LiftMaster 12Vdc 7AH (Part # MBAT).

TABLE OF CONTENTS

INTRODUCTION

Safety Symbol and Signal Word Review	3
Tools Needed For Installation	3
Unit Overview	3

UL325 MODEL CLASSIFICATIONS 4

SAFETY INSTALLATION INFORMATION 5

INSTALLATION

Concrete Pad	6
Anchors	6
Conduits	6
Dimensions	6

WIRING AND HOOKUP

AC Power Hookup (120/230 Vac)	7
Input Commands 1-8	7
Accessory and Relay Connections	8
Battery Installation	8
Master/Second Wiring	8

REVERSING ARM DIRECTION

Reversing the Direction of the Arm	9
------------------------------------	---

TIMERS AND MODE SELECTIONS S1 & S2

Mode Selections - S1	10
Fast Run Timer - S1	10
Close Timer Selection - S2	10
Mode Selections - S2	10

INSTALL THE RECEIVER

Wiring the Receiver	11
Set Security Mode	11
Programming the Remote to the Receiver	11
To Erase All Remote Control Codes	11

ADJUSTMENT

Instant Reverse Device (IRD)	12
Gate Arm Leveling	12

OPERATION AND MAINTENANCE

Important Safety Instructions	12
General Service	13
Shear Pin Replacement	13
Battery Disposal	13
Battery Replacement	13
Battery Maintenance/Testing	13
Battery Handling/Storage	13

TROUBLESHOOTING

Battery Checkout	14
Gate Not Operating	14
Troubleshooting Chart	14

SUGGESTED LOOP SENSOR LOCATIONS

Free Exit Operation	15
Entry With Access Control Device	15
Dual Direction	15

TRAP INSTRUCTIONS 16

SEQUENCE ACCESS MANAGEMENT SYSTEM (SAMS)

SAMS With Other Operators	17
SAMS Two Mega Arms with "Memory"	17

CONTROL BOARD LAYOUT

Input Locations	18
-----------------	----

MEGA ARM UL PARTS LIST

Part Numbers and Descriptions	19
Parts Shipped	19
Mega Arm Tower Unique Parts List	19
Mega Arm Options Parts List	19

ACCESSORIES 20

OPERATOR NOTES 21-22

WARRANTY POLICY AND REGISTRATION 23

REPAIR PARTS AND SERVICE 24

INTRODUCTION

WARNING

Mechanical

WARNING

Electrical

CAUTION

When you see these Safety Symbols and Signal Words on the following pages, they will alert you to the possibility of **serious injury** or **death** if you do not comply with the warnings that accompany them. The hazard may come from something mechanical or from electric shock. Read the warnings carefully.

When you see this Signal Word on the following pages, it will alert you to the possibility of damage to your gate and/or the gate operator if you do not comply with the cautionary statements that accompany it. Read them carefully.

UNIT OVERVIEW

The LiftMaster model MEGA ARM barrier style parking gate operator is unique in the industry. Setting the MEGA ARM apart are many features that make it the front runner in its class:

- Built in battery run - inherent 24 Vdc backup power with regulated 24 Vdc for accessories.
- High torque 24 volt Permanent Magnet DC motor.
- Full service controller with eight inputs and LED indicators for loops, card reader, radio, etc.
- Reversible arm direction for right or left handed operation.
- Instant Reverse Device (IRD) monitor senses obstructions during motion.
- Automatic open of gate arm when power is lost if desired (with 15 sec. delay selection).
- Raise gate input memory will memorize multiple vehicles – ideal for bar code scanners and AVI.
- Ability to STOP arm in close travel if tail-gating is sensed at close loop.
- Anti-tail gate alarm - fires K1 relay to trigger a warning device when tail-gating is sensed.
- SAMS with “memory” - allows Mega Arm to open a slide/swing gate first then raises arm.
- Break away mount design for the 12-15' x 3" tubular aluminum boom arm.
- Dynamic motor braking to preserve arm positioning.
- All rust proof aluminum construction with white powder coat baked on enamel.

IMPORTANT NOTE

- BEFORE attempting to install, operate or maintain the operator, you must read and fully understand this manual and follow all safety instructions.
- DO NOT attempt repair or service of your commercial door and gate operator unless you are an Authorized Service Technician.

TOOLS NEEDED FOR INSTALLATION

During assembly, installation and adjustment of the operator the tools listed below may be needed.

- Wrench or Socket Set
 - Phillips Head Screwdriver
 - C Clamps
 - Level
 - Small Screwdriver
 - T25 Torx Head Screwdriver
 - Molded Polyethylene UV stabilized cover never needs wax or paint (excludes towers).
 - Direct drive gear reducer eliminates many parts that might otherwise fail.
 - State of the art MOSFET motor drive technology, NO contactors or relays.
 - Soft start and stop in open and close travel motions.
 - No limit switches to fail - uses magnetic (Hall Effect) sensors to monitor arm position.
 - Maximum Run Timer for motor with anti-tamper protection in closing direction.
 - Each unit configurable as master or second operator.
 - Safe 24 Vdc low voltage motor and control wiring.
 - LED diagnostics for easy trouble shooting.
 - Closing timer adjustable from 1-31 seconds with on/off selection.
 - Transient voltage protection on all inputs.
 - Capable of being powered from 120 or 230 Vac, or UL Listed Class 2 Solar Power.
 - On 120 Vac installations, unswitched duplex outlet gives convenient supply for 120 Vac accessories.
 - 10 year perforation warranty on cover and chassis with 2 years on electronics and mechanism.
- NOTE:** *If the operator is installed in a region where temperatures regularly go below 30° F then it is recommended that the optional heater is installed. Refer to the accessory page.*

UL325 MODEL CLASSIFICATIONS

CLASS I – RESIDENTIAL VEHICULAR GATE OPERATOR

A vehicular gate operator (or system) intended for use in a home of one-to four single family dwellings, or a garage or parking area associated therewith.



CLASS II – COMMERCIAL/GENERAL ACCESS VEHICULAR GATE OPERATOR

A vehicular gate operator (or system) intended for use in a commercial location or building such as a multi-family housing unit (five or more single family units) hotel, garage, retail store or other building servicing the general public.

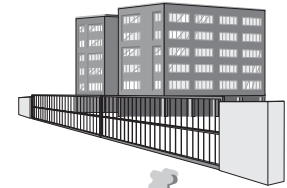

CLASS III – INDUSTRIAL/LIMITED ACCESS VEHICULAR GATE OPERATOR

A vehicular gate operator (or system) intended for use in a industrial location or building such as a factory or loading dock area or other location not intended to service the general public.

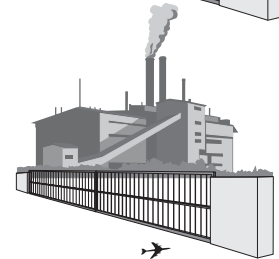

CLASS IV – RESTRICTED ACCESS VEHICULAR GATE OPERATOR

A vehicular gate operator (or system) intended for use in a guarded industrial location or building such as an airport security area or other restricted access locations not servicing the general public, in which unauthorized access is prevented via supervision by security personnel.

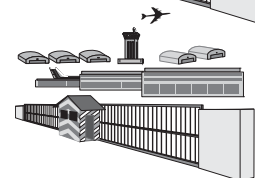

SAFETY ACCESSORY SELECTION

All UL325 compliant LiftMaster gate operators will accept external entrapment protection devices to protect people from motorized gate systems. UL325 requires that the type of entrapment protection correctly matches each gate application. Below are the six types of entrapment protection systems recognized by UL325 for use on this operator.

ENTRAPMENT PROTECTION TYPES

Type A: Inherent obstruction sensing system, self-contained within the operator. This system must sense and initiate the reverse of the gate within two seconds of contact with a solid object.

Type B1: Connections provided for a non-contact device, such as a photoelectric eye can be used as a secondary protection.

Type B2: Connections provided for a contact sensor. A contact device such as a gate edge can be used for secondary protection.

Type C: Inherent adjustable clutch or pressure relief valve.

Type D: Connections provided for a control requiring continuous pressure to operate the operator open and close.

Type E: Built-in audio alarm. Examples include sirens, horns or buzzers.

NOTE: UL requires that all installations must have warning signs placed in plain view on both sides of the gate to warn pedestrians of the dangers of motorized gate systems.



UL325 ENTRAPMENT PROTECTION REQUIREMENTS

GATE OPERATOR ENTRAPMENT PROTECTION

UL325 Installation Class	Slide Gate Operator		Swing & Gate Barrier (Arm) Operator	
	Primary Type	Secondary Type	Primary Type	Secondary Type
Class I & II	A	B1, B2 or D	A or C	A, B1, B2, or C
Class III	A, B1 or B2	A, B1, B2, D or E	A, B1, B2 or C	A, B1, B2, C, D or E
Class IV	A, B1, B2 or D	A, B1, B2, D or E	A, B1, B2, C or D	A, B1, B2, C, D or E

The chart above illustrates the entrapment protection requirements for each of the four UL325 classes.

In order to complete a proper installation you must satisfy the entrapment protection chart shown above. That means that the installation must have one primary means of entrapment protection and one independent secondary means of entrapment protection. Both primary and secondary entrapment protection methods must be designed, arranged or configured to protect against entrapments in both the open and close directions of gate travel.

For Example: For a slide gate system that is installed on a single-family residence (UL325 Class I) you must provide the following: As your primary type of entrapment protection you must provide Type A inherent (built into the operator) entrapment sensing and at least one of the following as your secondary entrapment protection: Type B1- Non-contact sensors such as photoelectric eyes, Type B2- Contact sensors such as gate edges or Type D- Constant pressure control.

SAFETY INSTALLATION INFORMATION

1. Vehicular gate systems provide convenience and security. Gate systems are comprised of many component parts. The gate operator is only one component. Each gate system is specifically designed for an individual application.
2. Gate operating system designers, installers and users must take into account the possible hazards associated with each individual application. Improperly designed, installed or maintained systems can create risks for the user as well as the bystander. Gate systems design and installation must reduce public exposure to potential hazards.
3. A gate operator can create high levels of force in its function as a component part of a gate system. Therefore, safety features must be incorporated into every design. Specific safety features include:
 - Gate Edges
 - Guards for Exposed Rollers
 - Photoelectric Sensors
 - Screen Mesh
 - Vertical Posts
 - Instructional and Precautionary Signage
4. Install the gate operator only when:
 - a. The operator is appropriate for the construction and the usage class of the gate.
 - b. All openings of a horizontal slide gate are guarded or screened from the bottom of the gate to a minimum of 4' (1.2 m) above the ground to prevent a 2 1/4" (6 cm) diameter sphere from passing through the openings anywhere in the gate, and in that portion of the adjacent fence that the gate covers in the open position.
 - c. All exposed pinch points are eliminated or guarded, and guarding is supplied for exposed rollers.
5. The operator is intended for installation only on gates used for vehicles. Pedestrians must be supplied with a separate access opening. The pedestrian access opening shall be designed to promote pedestrian usage. Locate the gate such that persons will not come in contact with the vehicular gate during the entire path of travel of the vehicular gate.
6. The gate must be installed in a location so that enough clearance is supplied between the gate and adjacent structures when opening and closing to reduce the risk of entrapment. Swinging gates shall not open into public access areas.
7. The gate must be properly installed and work freely in both directions prior to the installation of the gate operator.
8. Controls intended for user activation must be located at least six feet (6') away from any moving part of the gate and where the user is prevented from reaching over, under, around or through the gate to operate the controls. Outdoor or easily accessible controls shall have a security feature to prevent unauthorized use.
9. The Stop and/or Reset (if provided separately) must be located in the line-of-sight of the gate. Activation of the reset control shall not cause the operator to start.
10. A minimum of two (2) WARNING SIGNS shall be installed, one on each side of the gate where easily visible.
11. For a gate operator utilizing a non-contact sensor:
 - a. Reference owner's manual regarding placement of non-contact sensor for each type of application.
 - b. Care shall be exercised to reduce the risk of nuisance tripping, such as when a vehicle trips the sensor while the gate is still moving.
 - c. One or more non-contact sensors shall be located where the risk of entrapment or obstruction exists, such as the perimeter reachable by a moving gate or barrier.
12. For a gate operator utilizing a contact sensor such as an edge sensor:
 - a. One or more contact sensors shall be located where the risk of entrapment or obstruction exists, such as at the leading edge, trailing edge and post mounted both inside and outside of a vehicular horizontal slide gate.
 - b. One or more contact sensors shall be located at the bottom edge of a vehicular vertical lift gate.
 - c. A hard wired contact sensor shall be located and its wiring arranged so the communication between the sensor and the gate operator is not subject to mechanical damage.
 - d. A wireless contact sensor such as the one that transmits radio frequency (RF) signals to the gate operator for entrapment protection functions shall be located where the transmission of the signals are not obstructed or impeded by building structures, natural landscaping or similar obstruction. A wireless contact sensor shall function under the intended end-use conditions.
 - e. One or more contact sensors shall be located on the inside and outside leading edge of a swing gate. Additionally, if the bottom edge of a swing gate is greater than 6" (152 mm) above the ground at any point in its arc of travel, one or more contact sensors shall be located on the bottom edge.
 - f. One or more contact sensors shall be located at the bottom edge of a vertical barrier (arm).

INSTALLATION

CONCRETE PAD

The concrete pad for operator mounting should be approximately 24"x24"x24" in order to provide adequate weight and structure to insure proper and stable operation. Pad should be 6" above finished grade or even with top of curb if one is present. **(NOTE: Pad should always extend below frost line in regions where ground will freeze.)**

ANCHORS (MOUNTING UNIT)

Proper anchors for fastening operator to pad will be a 1/2"x6" wedge anchor patterned to match the mounting base of the unit. They should be installed with approximately 1 1/4" showing above concrete surface in order to allow for the 1/2" thick base plate as well as washers for leveling.

NOTES:

- For automotive use only, no motorcycles, bicycles or pedestrians.
- Heater option **MUST** be used if temperature is 30° or below.
- Heater option available for 120 Vac units only. See accessory page for heater part number.

CONDUITS

Conduits should be restricted to fit the 3 1/2"x3 1/2" opening in pedestal base and 10 1/4" x 8 1/4" for the tower base. Location on pad should be centered and spaced approximately 6" from edge of pad on drive way side (in order to get the most reach out of arm). Separate conduits to be included should be 120/230 Vac main power, low voltage control wiring and one or two extra for loop sensor leads. Conduit size should be limited to 1/2" when possible to reduce crowding if more than four are needed. All conduits must be UL approved.

TOWER CABINET DIMENSIONS

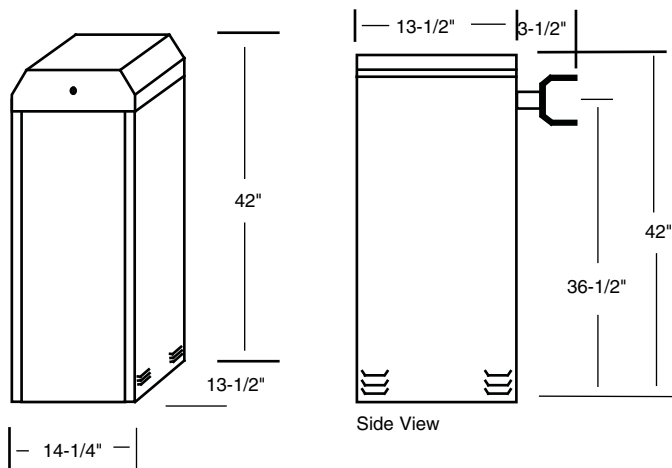

UNIT DIMENSIONS

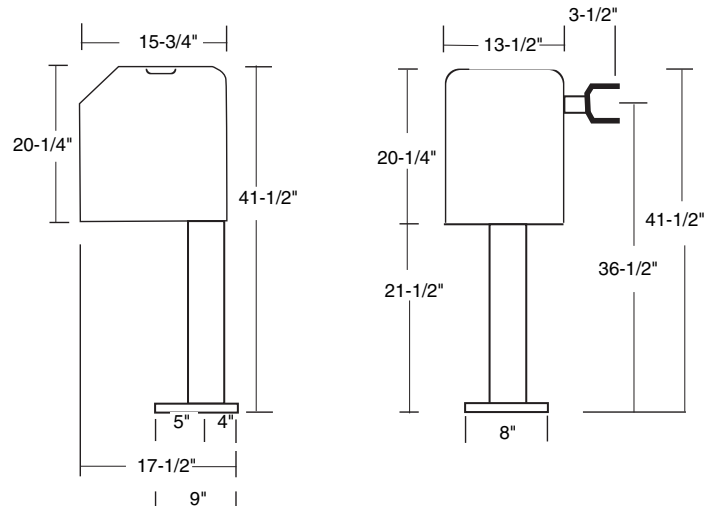

Pad (24"x24")

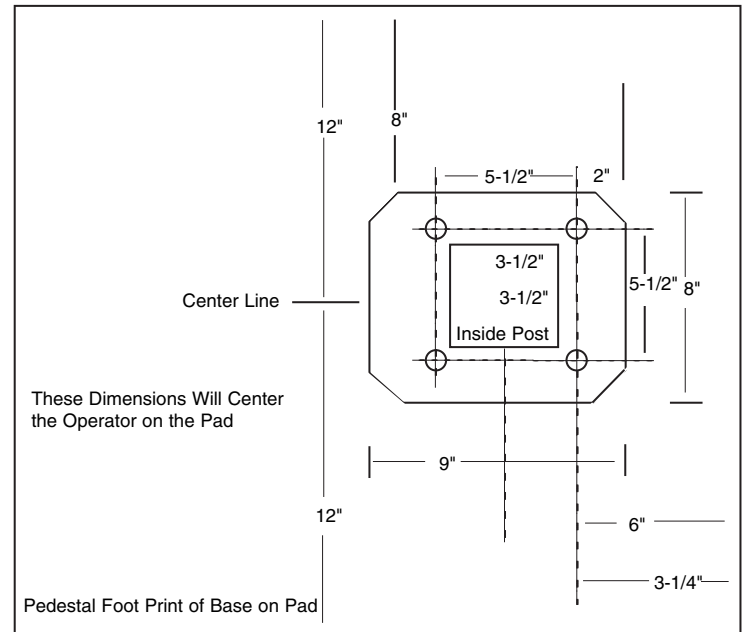

Pad (24" x 24" x 24")

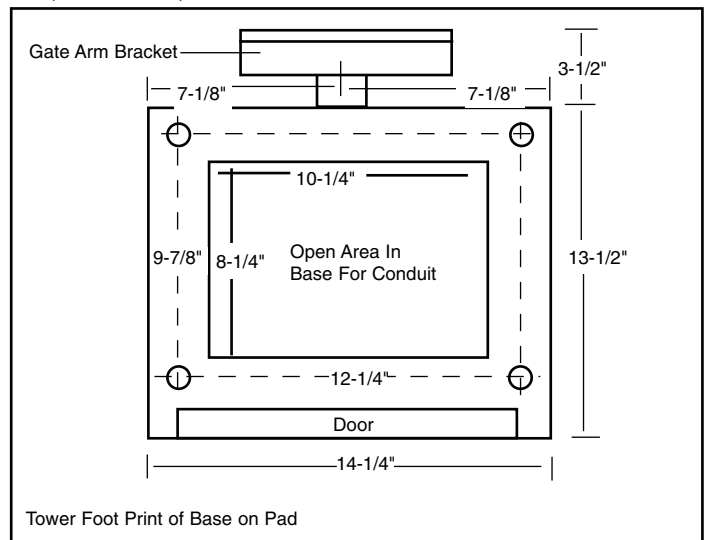

WIRING AND HOOKUP

WARNING

To reduce the risk of SEVERE INJURY or DEATH:

- ANY maintenance to the operator or in the area near the operator **MUST** not be performed until disconnecting the electrical power and locking-out the power via the operator power switch. Upon completion of maintenance the area **MUST** be cleared and secured, at that time the unit may be returned to service.
- Disconnecting power at the fuse box **BEFORE** proceeding. Operator **MUST** be properly grounded and connected in accordance with local electrical codes. **NOTE:** *The operator should be on a separate fused line of adequate capacity.*
- ALL electrical connections **MUST** be made by a qualified individual.
- **DO NOT** install any wiring or attempt to run the operator without consulting the wiring diagram. We recommend that you Install an optional reversing edge **BEFORE** proceeding with the control station installation.
- ALL power wiring should be on a dedicated circuit and well protected. The location of the power disconnect should be visible and clearly labeled.
- ALL power and control wiring **MUST** be run in separate conduit.
- **BEFORE** installing power wiring or control stations be sure to follow all specifications and warnings described below. Failure to do so may result in SEVERE INJURY to persons and/or damage to operator.

AC POWER HOOKUP (120/230 Vac)

Be sure your main power is OFF before attempting to hook up the AC power. The AC wiring should be attached to the wires exiting the conduit or pedestal post. Only use U.L. approved 14AWG (or larger) 600 volt insulated wire.

NOTE: Do not connect any of the AC power wires directly to the electronic control board. Connect the batteries after the AC power is restored.

INPUT COMMANDS CONNECTIONS

Use common and normally open contacts from devices connected to these inputs. Control wire connections at low voltage terminal strip will be at the top of the electronic control board. Make connections to the appropriate points for the desired operation, see Control Board Layout page 18. Wires should be UL approved 600 volt rated and at least 18 AWG. They are to be routed through the upper grommet in chassis to avoid chafing. All external control devices must have normally open dry contacts.

CAUTION: DO NOT CONNECT ANY DEVICE WHICH WOULD DELIVER ANY VOLTAGE OF ANY KIND TO THESE TERMINALS.

Terminals 9, 10, 11, 12 are the commons (0 Vdc) used to activate the following inputs:

- 1, 2, 3 OPEN:** These inputs will trigger gate open when pulsed or hold gate open with maintained contact. When released gate will close if closing timer is on or if close input is given.
- 4, AUXILIARY OPEN:** Same as 1, 2 and 3 with S2 switch 6 off. With S2 switch 6 on, this input will memorize multiple vehicles and not allow gate to close until the final vehicle in memory crosses the close loop. Use with laser scanners or card readers and (transmitters with timed anti-pass back). With S1 switch 5 on, this input becomes a momentary **pulse open, pulse close.**
- 5, SAFETY:** This input is generally not used with the MEGA ARM. If used its function is to make gate reverse and go back to the open position if it was closing. Input is disabled when gate is closed.

120 Vac

Connect the BLACK wire to the incoming 120 Vac hot lead and connect the WHITE wire to the incoming neutral lead. Connect the GREEN wire to the ground.

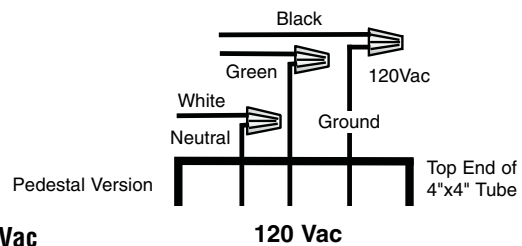

230 Vac

Please purchase the 120 to 230 Vac conversion kit for 230 Vac operation. See Accessory page.

6, CLOSE: When used with a vehicle detector, it is recommended that the presence contacts (N.O. & C.) be used for the close input. This input will close gate after input is applied and then removed. It will stop the open cycle and reverse gate to close. (Example: Car crosses over close loop before arm reaches full open position- gate will reverse and close). **(NOTE: The close input also acts as a safety-stop in that if gate is closing and a tailgater is sensed at the close input, the gate WILL STOP its closing motion and not continue to close until the close input is removed or gate is re-opened).**

7, BACK-AWAY (FREE EXIT INPUT): This input is used as a free exit input to open gate. When input is active, gate will open and close immediately once input is removed. (EXAMPLE: Car pulls up to exit loop, gate opens; car "backs-away" from exit loop and gate closes).

8, SHADOW (SAMS): Used to monitor an auxiliary open limit switch of another operator in the same lane. SAMS with memory feature, see page 18.

9, 10, 11, 12 - COMMON: These are the commons (0 Vdc) to be used to activate above inputs.

NOTE: Above inputs are tied to LED indicators to show input command activity.

ACCESSORY AND RELAY CONNECTIONS

These terminals will provide battery backed power to 24 Vdc devices and are located at the bottom of the electronic control board at J4 terminals 1 and 2. Terminal 1 is 24 Vdc (+) and number 2 is 0 Vdc (-). Peripheral CLASS 2 low voltage devices that require 24 Vdc power maybe connected here (500 ma. maximum). EXAMPLE: Vehicle detector, radio receiver.

RELAY OUTPUT K1 - (OPTION)

S1-6 off S1-8 off, relay will fire (latch) when gate is not closed.

S1-6 on S1-8 off, relay will fire when arm is pushed up off of limit switch (use with slip clutch option) and fires relay when a tail-gate is detected by the close loop - ANTI TAIL-GATE ALARM.

S1-6 off S1-8 on, relay will pulse relay when arm reaches full open position.

S1-6 on S1-8 on, relay will only pulse when input is given to J5 1,2,3 inputs. (see page 10).

BATTERY INSTALLATION

HOOKING UP BATTERY LEADS - ALWAYS HOOKUP AND TURN ON AC POWER BEFORE INSTALLING BATTERIES. After turning on AC power, install two new, fully charged 12 volt DC batteries on shelf next to motor. Connect red lead from operator to the positive (RED +) terminal of one battery and black lead from the operator to the (BLACK -) terminal of the OTHER battery. Place the supplied jumper between the remaining terminals of each battery if one is not already in place (Figure 1). (Use LiftMaster MBAT or 29-NP712 for replacement batteries.) Replace in pairs.

WARNING: Do not run operator without installing the batteries.

MASTER/SECOND WIRING

STEP 1: In a master/second configuration, either unit can be the master. Choose one unit to be the master and then direct all control wiring to it (also install vehicle detectors and receivers in it).

STEP 2: At the MASTER, any input (at J5) with control (detectors, receivers, keypads, timers, etc.) wires to it must also be run to the same terminals of the second. Along with these control wires, both operators MUST share a common ground connection from chassis to chassis (or from common to common, i.e., master gate J5 terminal #12 to second gate J5 terminal #12).

EXAMPLE: If only open and close are used at master then three wires will run between gates (Figure 2).

STEP 3: If it is required that if one gate senses an obstruction, the other reverses also, then 3 additional wires must be run between the master J3 and second J3 (Figure 3). These connections are for transmitting IRD (obstruction signals) between both units. This will allow the master or second to inform the other that a closing obstruction has occurred and for it to reverse and open. SET switches on S2, 1-8 the same on both gates.

FIGURE 1

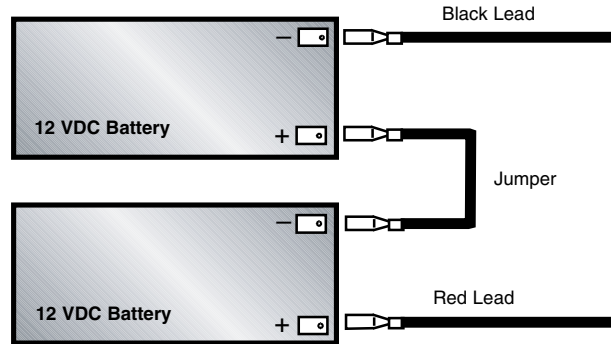

Failure to install batteries correctly will cause damage and will not be covered by warranty.

FIGURE 2

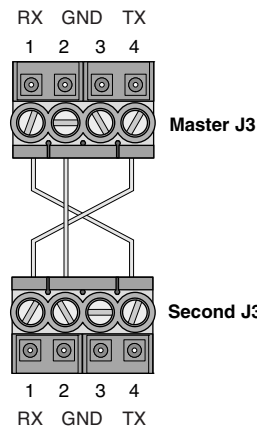
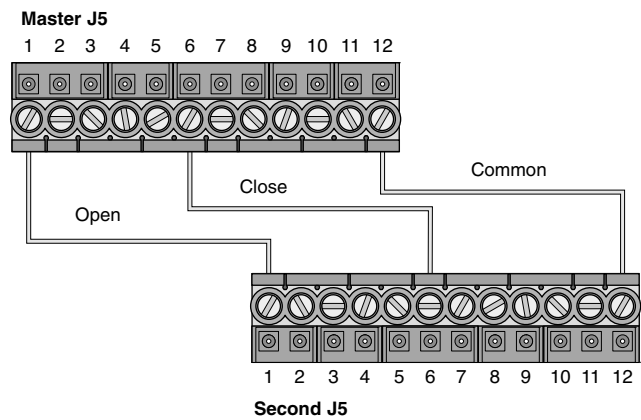

IRD - Obstruction Signal Connections
Terminal 1 of Master must go to terminal 4 of Second and terminal 1 of Second must go to terminal 4 of Master. Terminal 2 of Master must go to terminal 2 of Second.

REVERSING ARM DIRECTION

REVERSING THE DIRECTION OF THE ARM

The MEGA ARM allows for the “handing” or reversing of the arm’s direction of movement in relation to the unit’s normal operation. This allows for mounting in tight places or when it is desired to have the arm, when across the driveway, to be in front of the unit or behind the unit when viewed from the traffic flow direction (Figure 1).

WARNING: POWER MUST BE OFF AND NO ARM INSTALLED BEFORE MAKING THESE CHANGES.

STEP 1: Before power up, switch bank S1 switch #7 must be on (Figure 1).

STEP 2: Next, the motor wires on the control board must be reversed. At J4 on the bottom of PCB, the last 2 wires on the right (J4-7, J4-8) normally are blue then orange. They must be reversed to be (J4-7) orange then (J4-8) blue (Figure 2).

STEP 3: After completing the steps above, the cam arm which adjusts the limiting points of the arm’s travel must be turned 90 degrees to the left when viewed while standing in front of the control board (Figure 3) (cam arrow now points in the direction of the arm and is level with mount bracket, note the small limit sensors on the back of the PCB).

STEP 4: Now check to make sure that S1 #7 is on (Figure 1), motor wires are reversed, the cam is adjusted, and that the manual open/close switch (S3) is set to close. Next, turn on the AC power and connect the batteries. Now run the gate open and close with the S3 manual switch making sure that the mechanism travels in the proper 90 degrees desired. Once you are totally sure you have the correct operation, you can install the arm

INSTALLATION NOTE: ARMS LONGER THAN 12' MUST USE THE PROPER COUNTER WEIGHT.

FIGURE 1

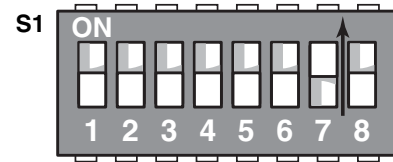

S1, #7 to be turned ON before power up to enable reverse of arm.

FIGURE 2

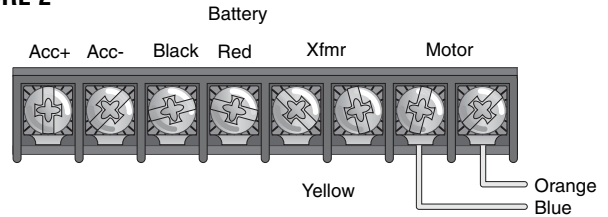
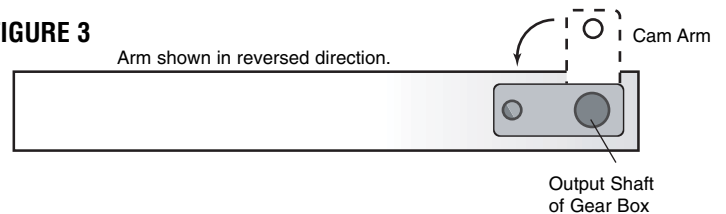

FIGURE 3



TIMERS AND MODE SELECTIONS S1 & S2

MODE SELECTIONS - SWITCH PACK S1 (5-8)

SWITCH 5: ON -Will allow J5 input #4 to operate as a pulse open/pulse close function.

SWITCH 6: ON -Will fire relay if gate is pushed UP from closed limit, used with clutch option. Also

ANTI TAIL-GATE ALARM, if tailgating is detected by close loop, K1 relay will fire. When using clutch option, turning on S1-6 & S2-7, gate will close by timer whenever forced up.

SWITCH 7: Used to enable arm to work in reverse direction, see page 9.

SWITCH 8: Off will make K1 relay activate during open cycle (use with buzzers, counters, etc.). On will pulse K1 relay when OPEN LIMIT (OLS) is reached (activates a swing or slide gate its lane).

See also page 18, **RELAY OUTPUT-K1**

FAST RUN TIMER - SWITCH PACK S1 (1-4)

The fast run timer sets the time that the operator runs at full speed. The slow start ramp time is fixed. The slow stop ramp time is fixed but can be overrun by the fast run time if not adjusted properly. When adjusting make sure the slow stop ramp completes before the close limit. With all switches off, the default fast run time is 1.5 seconds. Changing settings will adjust fast run timer by 1/8 second increments. (Example: #2 on equals .25 seconds, #4 on equals 1 second. #2 and #4 on equals 1.25 seconds, etc.)

CLOSE TIMER - SWITCH PACK S2 (1-5)

NOTE: Default setting is off.

On the MEGA ARM the switches 1-5 on S2 are for the closing time delay to select the period of time that the gate stays open after the obstruction sensor has reversed and re-opened the arm or if the S2-7 timer to close is turned on. The default will keep the gate up for 4 seconds to allow the vehicle to be moved from the gate arm path. Changing settings 1 - 5 will increase or decrease this hold open time. The default of **3 ON and 1, 2, 4, 5 OFF** will provide a 4 second close time delay.

MODE SELECTIONS - SWITCH PACK S2 (6-8)

SWITCH 6 - INPUT MEMORY: Activates multiple vehicle memory at auxiliary input terminal #4 on J5.

SWITCH 7 - AUTO CLOSE TIMER: Default is **OFF**. On will close gate by timer when all inputs are cleared. Time is set by using S2 1-5 switches. (WARNING: Special care should be used to avoid arm from closing on cars. Use safety loops, stop loops, photo beams and a long enough time delay.)

NOTE: Can be used with multiple vehicle memory buffer to allow gate to close and reset count memory to zero. When using clutch option, turning on S1-6 & S2-7, gate will close by timer whenever forced up.

SWITCH 8 - AUTO OPEN ON POWER FAILURE: When switch number 8 is in the **ON** position, the operator will automatically open the gate approximately 15 seconds after the loss of power. Once power is restored the operator will resume normal operation after the first car passes closing loop or if close timer S2-7 in turned on (it is recommended to allow the gate to close by loop, not by timer).

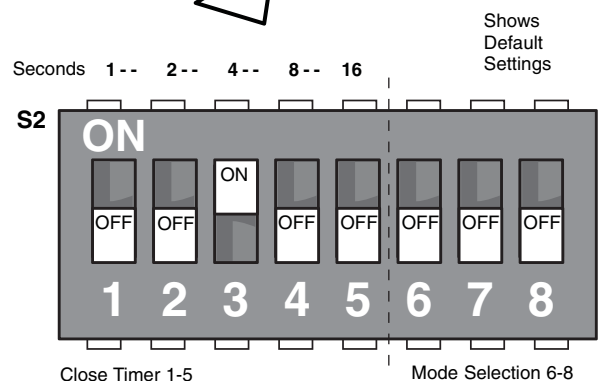
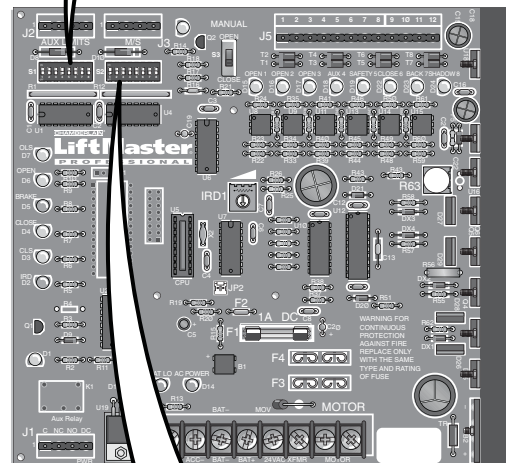
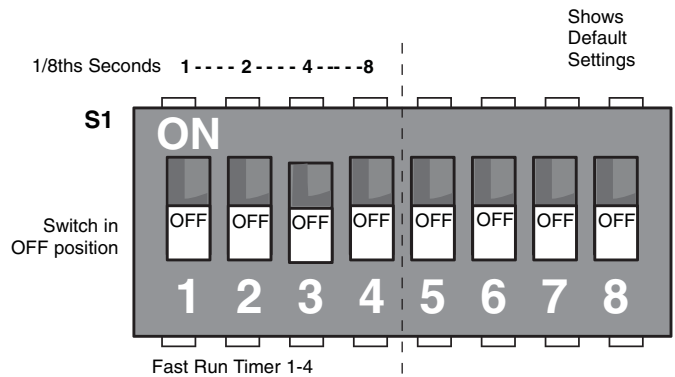

INSTALL THE RECEIVER

WARNING

To prevent possible **SERIOUS INJURY** or **DEATH** from a moving gate or garage door:

- **ALWAYS** keep remote controls out of reach of children. NEVER permit children to operate, or play with remote control transmitters.
- Activate gate or door **ONLY** when it can be seen clearly, is properly adjusted, and there are no obstructions to door travel.
- **ALWAYS** keep gate or garage door in sight until completely closed. NEVER permit anyone to cross path of moving gate or door.

NOTICE: To comply with FCC and/or Industry Canada (IC) rules, adjustment or modifications of this receiver and/or transmitter are prohibited, except for changing the code setting or replacing the battery. **THERE ARE NO OTHER USER SERVICEABLE PARTS.**

Tested to Comply with FCC Standards FOR HOME OR OFFICE USE. Operation is subject to the following two conditions: (1) this device may not cause harmful interference, and (2) this device must accept any interference received, including interference that may cause undesired operation.

WIRING THE RECEIVER

Contacts 1 and 2 on the receiver terminal strip are for power. The power terminals are unpolarized. Connect terminals 1 and 2 to the accessory power terminals on the J4 terminal strip at the bottom of the logic board (Figure 1).

Contacts 3 and 4 on the receiver terminal strip are for a common and a relay. Connect terminals 3 and 4 to terminals 1 and 10 on the J5 terminal strip at the top of the logic board.

NOTE: Auxiliary Pin 4 can be used for push to open/push to close functionality.

SET SECURITY MODE

The Universal Receiver can be used with up to 15 rolling code remotes or passwords in **HIGH** security mode. Alternately, it can be used with up to 31 of any type remote in **NORMAL** security mode, including any combination of rolling code, billion code (390Mhz only), or dip switch remotes.

The jumper must be set at the **HIGH** position for the receiver to operate in **HIGH** security mode. It must be set at **NORMAL** position to operate at the **NORMAL** mode (Figure 2).

When changing from **NORMAL** to **HIGH** security mode, any previous remote codes must be erased. Repeat Steps 2 and 3 in the Programming Section below to reprogram the receiver for each remote control in use.

The receiver is factory set at **HIGH**.

PROGRAMMING THE REMOTE TO THE RECEIVER

STEP 1: Pry open the front panel of receiver case with a coin or a screwdriver. Re-connect power to opener (Figure 3).

STEP 2: Press and release the “learn” button on the receiver. The learn indicator light will glow steadily for 30 seconds.

STEP 3: Within 30 seconds, press and hold the button on the hand-held remote that you wish to operate your gate.

The opener will now operate when the push button on either the receiver or the remote control is pressed.

Repeat Steps 2 and 3 for each remote control that will be used to operate the gate.

TO ERASE ALL REMOTE CONTROL CODES

Press and hold the “learn” button on the receiver panel until the indicator light turns off (about 6 seconds). All remote codes are now erased. Then follow the steps above to reprogram each remote control.

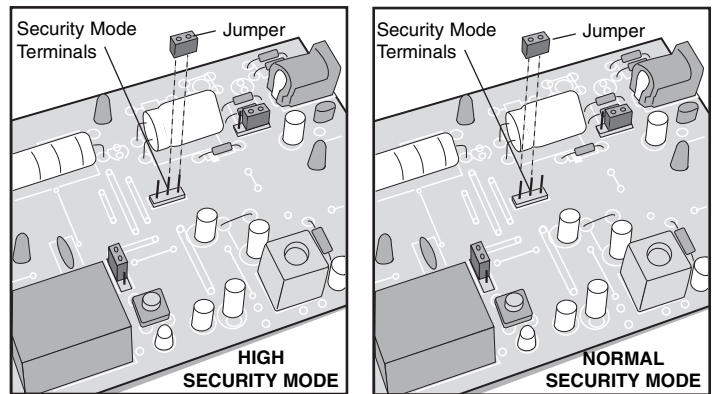
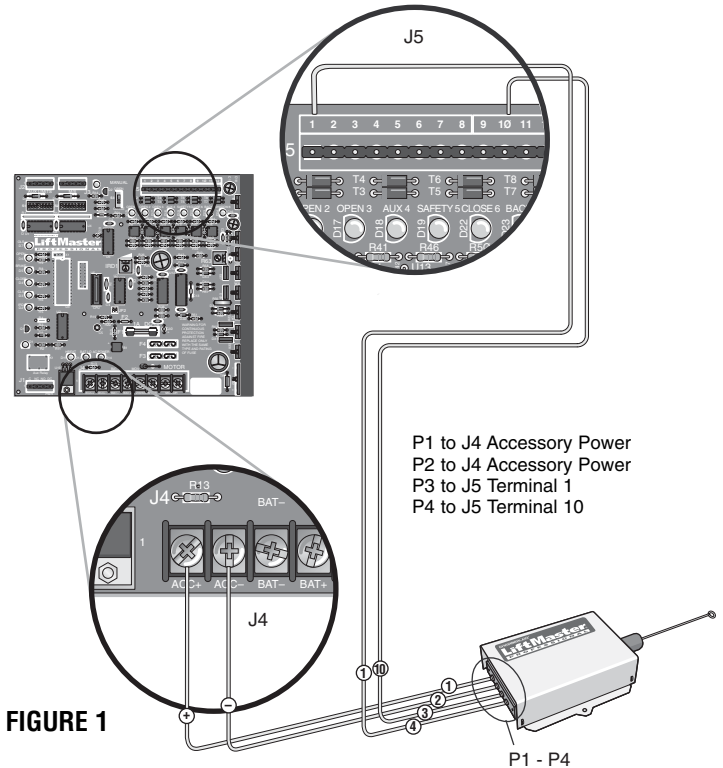

OPENING RECEIVER

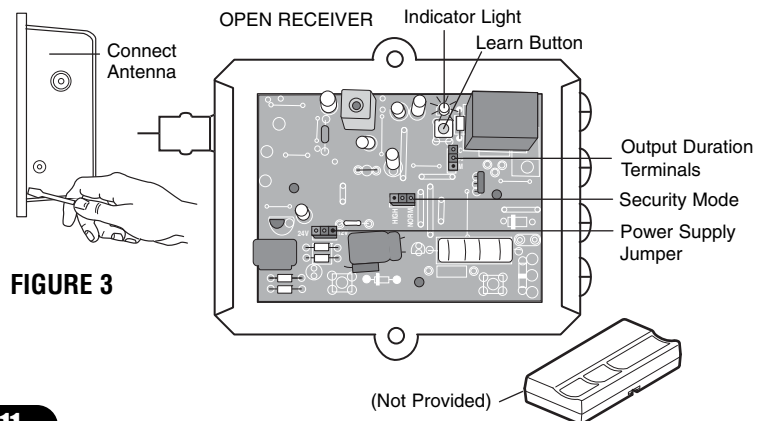

ADJUSTMENTS

INSTANT REVERSE DEVICE (IRD)

The reverse device is an internal circuit that continuously monitors the motors current for increased draw. Turning the IRD1 right (CW more sensitive), or left (CCW less sensitive) in small increments will allow sensitivity adjustments (IF ARM DOES NOT REVERSE, DO NOT CONTINUE TO FORCE). The obstruction that you apply should STOP the arm. Adjust sensitivity so that consistent reversal occurs. If the gate stops while opening then the **IRD** is TOO sensitive.

Some slight adjustment either way may be needed so that the gate only reverses when obstructed. If gate is obstructed while closing, the gate will reverse to the open position, time out (using the time delay set at S-2 switches 1-5) and then close. If gate is opening when obstructed, gate will stop its open travel, then will time out and close using the same delay set at S-2.

If S-2 switch number 8 is off (you have programmed the unit to **NOT AUTO RAISE** when power fails), then recheck your adjustments with AC power off to be sure proper operation will be maintained.

NOTES: Instant reverse device (IRD) should be tested monthly to insure proper operation. If adjustments are required, refer to above paragraph.

Adjustments to be done by qualified service persons only.

WARNING

To reduce the risk of SERIOUS INJURY or DEATH:

- Disconnect power BEFORE performing ANY adjustments near drive shaft.

GATE ARM INSTALLATION AND LEVELING

Install arm in gate arm bracket by lining up holes in arm with the slotted holes in bracket. Insert the bolts through the arm and through the bracket. Next install the flat washers then the nylon nuts. (It is recommended the only nylon nuts be used to attach arms).

The magnetic limit cam is pre-adjusted for near proper arm travel, however if leveling of the arm is required this can be done through adjustment to the magnetic cam arm. Note that limit range can be impacted from 85 to 89 degrees by sliding the main board up and down in its slot. Always adjust for a level arm in the **HORIZONTAL POSITION**. There is a small set screw in the side of the cam arm which can be loosened to allow the cam arm magnet to reach the close limit sensor (located on back of controller, H2) earlier or later in its travel.

Continue to open and close the gate while adjusting until a satisfactory horizontal stopping point can be maintained. Afterwards re-secure set screw in cam arm. **NOTE:** In some cases additional adjustments may be required after the belt wears in. When stopping in the open position, the arm will stop just before the full vertical position.

NOTE: To prevent entrapment, allow for two (2) feet minimum clearance past end of arm when in down position.

OPERATION AND MAINTENANCE

IMPORTANT SAFETY INSTRUCTIONS

WARNING

To reduce the risk of SEVERE INJURY or DEATH:

1. READ AND FOLLOW ALL INSTRUCTIONS.
2. NEVER let children operate or play with gate controls. Keep the remote control away from children.
3. ALWAYS keep people and objects away from the gate. NO ONE SHOULD CROSS THE PATH OF THE MOVING GATE.
4. Test the gate operator monthly. The gate MUST reverse on contact with a rigid object or stop when an object activates the non-contact sensors. After adjusting the force or the limit of travel, retest the gate operator. Failure to adjust and retest the gate operator properly can increase the risk of INJURY or DEATH.
5. Use the emergency release ONLY when the gate is not moving.
6. KEEP GATES PROPERLY MAINTAINED. Read the owner's manual. Have a qualified service person make repairs to gate hardware.
7. The entrance is for vehicles ONLY. Pedestrians MUST use separate entrance.
8. Disconnect ALL power BEFORE performing ANY maintenance.
9. ALL maintenance MUST be performed by a LiftMaster professional.
10. **SAVE THESE INSTRUCTIONS.**

OPERATION AND MAINTENANCE

Check at the intervals listed in the following chart:

ITEM	PROCEDURE	EVERY 3 MONTHS	EVERY 6 MONTHS	EVERY 12 MONTHS	EVERY 24 MONTHS
Fasteners	Check and tighten as required.		●	◆	
Bearings & Shafts	Check for wear and lubricate.	●		◆	
Battery Maintenance	Replace batteries.				●

◆ Repeat ALL procedures.

GENERAL SERVICE

1. Belt loose or needs replacement, adjust with 4 bolts that support motor to allow 1/4" play.
2. Charge voltage for batteries should be 27.5 +0.05, -0 Vdc with batteries disconnected (set with R63, shown on the Control Board Layout page).
3. Replace batteries with Liftmaster P/N MBAT batteries. Replace in pairs.

SHEAR PIN REPLACEMENT

If gate arm is vandalized and the tapered pin in the output shaft has been sheared, it must be replaced correctly and with the right pin type. Replacement must be done by always punching out the pin (or pieces) from the small end only. If drilling is required, DO NOT DAMAGE THE SHAFT, use a drill bit smaller than the small hole size of the pin. (Correct pin (P/N MA013) is a 2" pin with a number 6 taper only.)

NEVER USE A BOLT AS A TEMPORARY FIX, THIS WILL DAMAGE THE SHAFT AND COLLAR

1. Use S-3 to rotate bracket to up position
2. Turn off AC power and disconnect batteries small end first.
3. Remove gate arm bracket and pieces in collar
4. Drive out pin pieces with hammer and punch (Solid sharp blows are better than light ones)
5. Reinstall gate arm bracket
6. Lightly oil the new pin then insert into collar
7. Fully seat pin in shaft by taping on large end
8. Reinstall the arm if required
9. Turn on AC power and connect batteries
10. Turn off S-3 to put gate into operation

WARNING

To avoid SERIOUS PERSONAL INJURY or DEATH from electrocution, disconnect ALL electric power BEFORE performing ANY maintenance.

BATTERY DISPOSAL

Replaced batteries must be treated as a hazardous waste and disposed of in accordance with State, Local and Federal Regulations. See the battery manufacturer's Material Safety Data Sheets (01-30839 "MSDS Sheets, Battery, Standard").

BATTERY REPLACEMENT

Service Kits are available for battery replacement. Please contact Technical Support (see back of this document for contact information).

BATTERY MAINTENANCE / TESTING

The batteries are maintenance free. However, to insure proper and safe operation, it is recommended that the batteries be replaced every two years. Battery testing is conducted automatically. See the Battery Test Description section for manually initiating the battery test.

BATTERY HANDLING / STORAGE

Refer to the battery manufacturer's Material Safety Data Sheets (01-30839 "MSDS Sheets, Battery, Standard"). LiftMaster does not recommend storage of batteries in the field. Batteries are intended for immediate use.

TROUBLESHOOTING

WARNING - DISCONNECT BATTERIES AND AC POWER BEFORE SERVICING ANY MECHANICAL OR MOVING COMPONENTS.

BATTERY CHECKOUT

When the batteries become weak the gate will begin to run noticeably slower. **NOTE:** Batteries should only be checked when you are sure they have had adequate time to fully charge. Turn off the AC power and run gate for 5 to 10 cycles while observing low battery indicator LED D12. If LED 12 comes ON, batteries are too weak to function properly. If LED 12 does not light, then voltage should be checked as they still maybe near failure. Correct voltage is approximately 24.5Vdc. **NOTE:** If LED D12 does light, gate will open to conserve batteries in this test or in a real power loss, even if mode switch 8 on S2 is off. Return of AC power will clear low battery indicator. Correct charge voltage is 27.5 Vdc with batteries not connected (set with R63, shown on the Control Board Layout page).

GATE NOT OPERATING

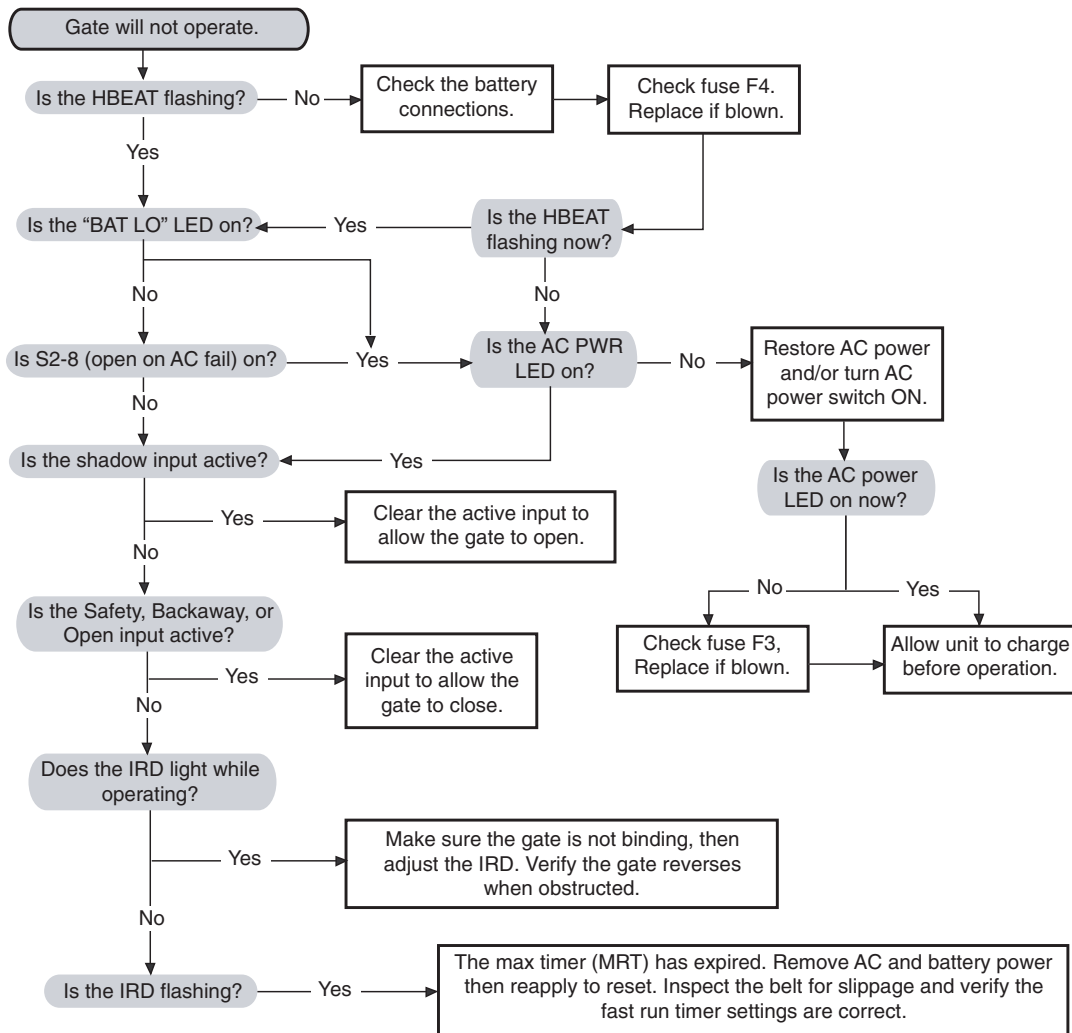

SUGGESTED LOOP SENSOR LOCATIONS

FREE EXIT ON VEHICLE APPROACH

Gate will open when sensed by exit loop and then close once the close loop is cleared. If the vehicle pulls up to the exit loop and then backs away, it will close (Figure 1).

Space between loops will be 4' to 10'.

Terminal #7 is backaway (free exit).

Terminal #6 is close input.

FIGURE 1

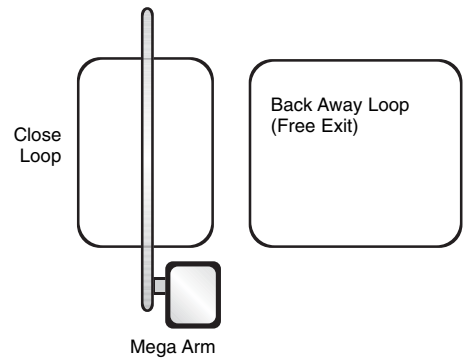

ENTRY WITH ACCESS CONTROL DEVICE

Gate will open when activated by an access control device. When vehicle passes and clears close loop, gate will close (Figure 2).

NOTE: If a second vehicle tail-gates and is sensed at the close loop, gate will stop its closing motion until loop is cleared again.

Terminal #6 is close input.

Terminals #1, 2, and 3 are open inputs.

FIGURE 2

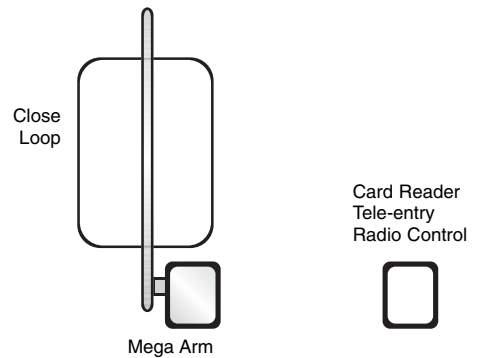

DUAL DIRECTION AS ENTRY OR FREE EXIT

Dual direction is a combination of both of the above configurations to provide the ability for traffic to enter or exit in the same lane (Figure 3).

Space between loops will be 4' to 10'.

DO NOT ALLOW CONTROL DEVICES TO BE WITHIN 10' OF GATE OR OPERATOR

RECOMMENDATION 1: If vehicle detectors are used to open or close the gate, use of the presence contacts are recommended. Using the pulse contacts will **REDUCE** the gate's safe operation.

RECOMMENDATION 2: If closing timer is to be used, use **ONLY** on a dedicated free exit.

RECOMMENDATION 3: Close loop must be centered under gate arm.

FIGURE 3

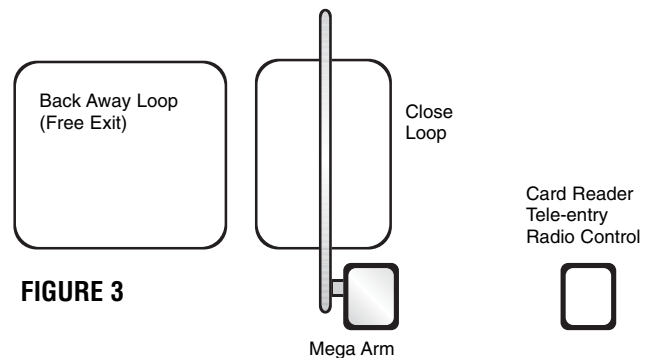

TRAP INSTRUCTIONS

INSTALL THE K1 AUXILIARY RELAY AND CONNECTOR AT MEGA ARM CONNECTED TO THE ACCESS DEVICE

1. Press the relay into the K1 location ensuring the pins are properly aligned.
2. Press the connector into the J1 connector pins.

INSTALL THE K1 AUXILIARY RELAY AND CONNECTOR AT THE SECOND

1. Press the relay into the K1 location ensuring the pins are properly aligned.
2. Press the connector into the J1 connector pins.

WIRE THE CONNECTIONS BETWEEN THE OPERATORS

1. Connect the Normally open output (NO) of the K1 relay on the trap unit to the OPEN input (J5 - term#2) of the second unit.
2. Connect the common output (C) of the K1 relay of the trap unit to the common of the second unit (J5 - term#12).
3. Connect the Normally open output (NO) of the K1 relay on the second unit to the INTERLOCK input of the trap unit (J5 - term#8).
4. Connect the common output (C) (J5 - term#12) of the second unit to the common of the trap unit (J5 - term#12).

SET THE DIP SWITCHES AT THE TRAP OPERATOR

1. Set switch bank S1 to 00100001 where 1 is up and 0 is down.
2. Set switch bank S2 to 00100010 where 1 is up and 0 is down.

SET THE DIP SWITCHES AT THE SECOND OPERATOR

1. Set switch bank S1 to 00100000 where 1 is up and 0 is down.
2. Set switch bank S2 to 00100010 where 1 is up and 0 is down.

RECONNECT THE POWER AND TEST

1. Reconnect the DC power by replacing the neutral (Black) wire to the battery terminal.
2. Reconnect the AC Power to the operator.
3. To test, activate the following sequence of inputs:
 - a. Open the trap gate using the access device.
 - b. When the trap gate is open, activate the close loop on the trap operator. The trap gate will close and the second gate should open.
 - c. When the second gate is open, activate the close loop on the second operator. The second gate should close.

TRAP SET UP

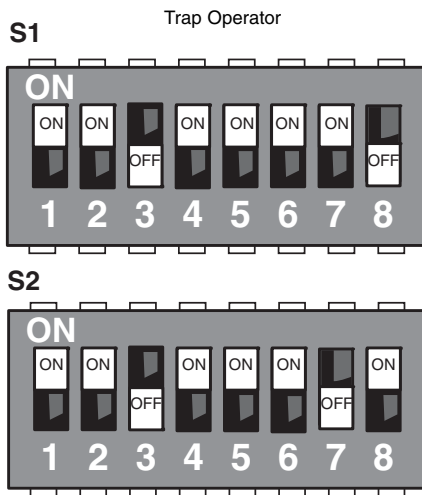
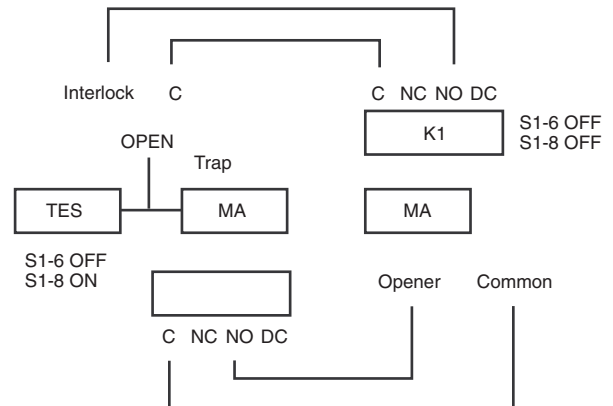

TRAP CONFIGURATION
Must use trap kit. See Mega Arm Options Parts List

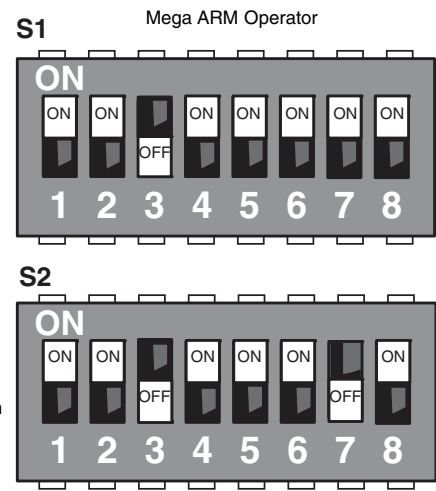
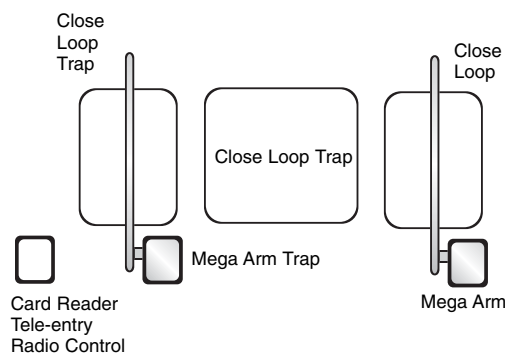

SEQUENCE ACCESS MANAGEMENT SYSTEM (SAMS) WITH "MEMORY"

SAMS WITH OTHER OPERATORS

REQUIRES THE K1 RELAY OPTION (Order SAMS KIT)

This feature allows a logical interface between the MEGA ARM barrier gate and a swing, slide, etc. gate operator (or MTC-31). All that is required is 4 wires between the MEGA ARM barrier gate and the other operator. It will be necessary to have one set of dedicated/isolated dry contacts - {C. and N.C.} COMMON and NORMALLY CLOSED be available at the other operator's OPEN LIMIT SWITCH. Most units will require that this EXTRA limit switch be added to their open limit switch assembly (Figure 1).

OPERATION: A one second pulse from access control device to the MEGA ARM will energize its K1 relay sending an open signal to the other operator causing it to open. However, the MEGA ARM's boom will not raise yet. When the other operator reaches its full open limit switch, this will open the COMMON and NORMALLY CLOSED contact on the EXTRA open limit switch. This will allow the original signal from your access control device (that was stored in memory) to now raise the gate arm. As long as the other operator is in the full open position, any additional open pulse sent will in turn energize the MEGA ARM's K1 relay to send another open signal to the other operator as well as cause the arm to raise again if it has closed via a car crossing the MEGA ARM's close loop.

WIRING: Run 2 wires from the other operator's isolated common & normally closed contacts of its open limit switch to the MEGA ARM J5#8 and one of the commons J5, #9-12. Next, run 2 wires from the MEGA ARM's K1 relay (common & normally open) to the other operators common and open input. (WARNING: max of 30 VOLTS at .5 amps through relay). J5 #8 was the unused SHADOW LOOP input on the MEGA ARM.

NOTE: A separate open device (24 hour timer, toggle switch) can be run to the other operator to control it without raising the gate arm. Tampering with the other operator's safety loops, safety edges and reverse sensors WILL NOT cause the arm to raise if one tripped. The arm will only raise if an intended open signal was sent to the MEGA ARM.

NOTES: For motorized teeth, vertical pivot or overhead operator, leave S1-6, S1-8 OFF (this will keep the K1 relay latched down until the arm reaches the down position. This will keep the other gate operator locked open or teeth locked down until the arm closes completely).

In this mode, if the arm senses an impact, the K1 relay will stay energized holding open (or teeth down) the other operator until the arm times out and closes.

SAMS TWO MEGA ARMS WITH "MEMORY"

REQUIRES THE K1 RELAY OPTION (Order SAMS KIT)

NOTE: Can be used when you have two entry gates that you want to **SEQUENCE** with each other. This is when you can only have **ONE** gate raised at a time (bottle neck or gates at a cross street). In this case, which ever one raises first will get first priority, while if the other gets an open signal, it will be **HELD IN MEMORY**, then raise once the first gate closes. This will work if either gate has a telephone entry unit or access device (AVI, prox, etc.).

Connect the K1 relay C and N.O. of each gate to the SHADOW LOOP J5 #8 input and common of the other (Figure 2). (Leave S1-6 and 8 OFF to allow relay to stay latched.)

NOTE: Insert a jumper across the JP2 terminal to allow the SAMS feature to work with the multiple vehicle memory count selection, use the K1 relay to open the sequenced gate (S1-5 off, S2-6 on, jumper across JP2). This allows gate to store input counts via J5 #4 but not raise the arm until the sequenced slide or swing gate has fully opened.

FIGURE 1

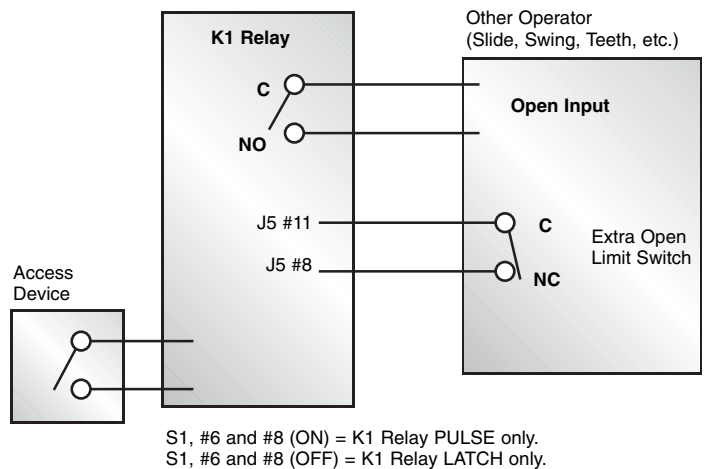
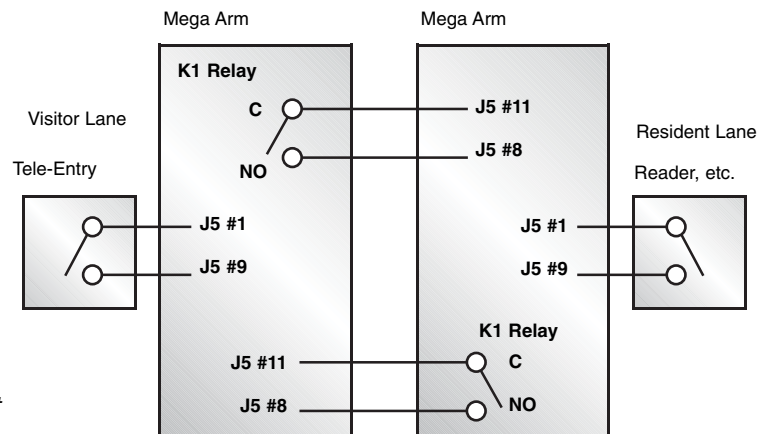
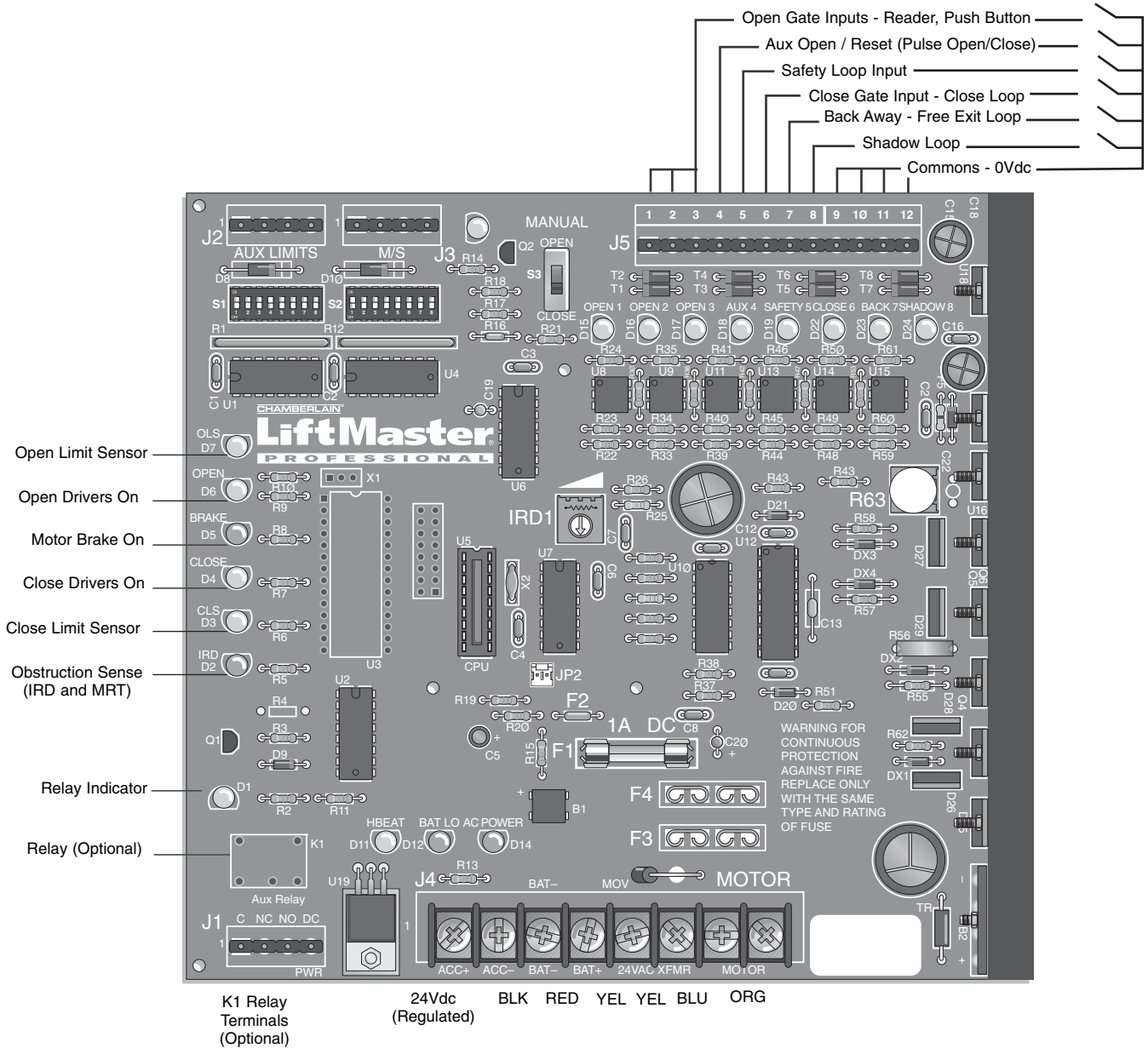

FIGURE 2



CONTROL BOARD LAYOUT



INPUT LOCATIONS

Accessory power is 24Vdc regulated rated at 500 ma. [1/2 amp].

NOTE: J5 #8 is now the SAMS with memory input (see page 12).

D11: Heart beat. Shows that processor and program are running properly.

D12: Battery status. See diagnostic procedures.

D14: AC power indicator. Shows that AC power is present.

S3: Manual open. To allow gate to be opened or closed during service of unit. Keep in the “Close” position for normal operation.

F3: 10 amp ATO type fuse for 24Vac input power. (UL listed fuse only.)

F4: 15 amp ATO type fuse for 24Vdc battery input power. (UL listed fuse only.)

MEGA ARM UL PARTS LIST

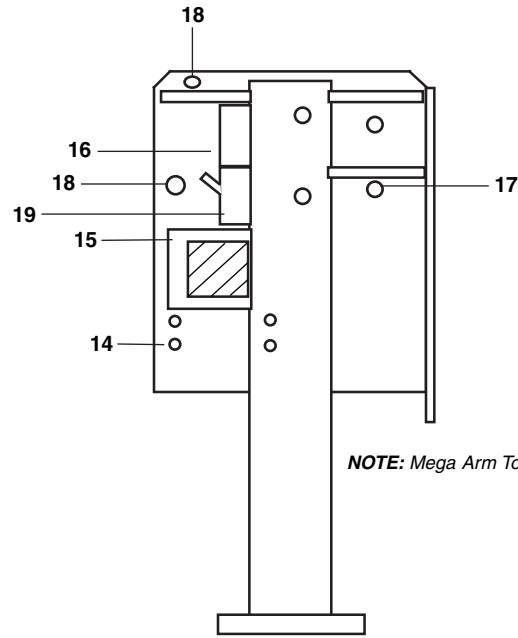
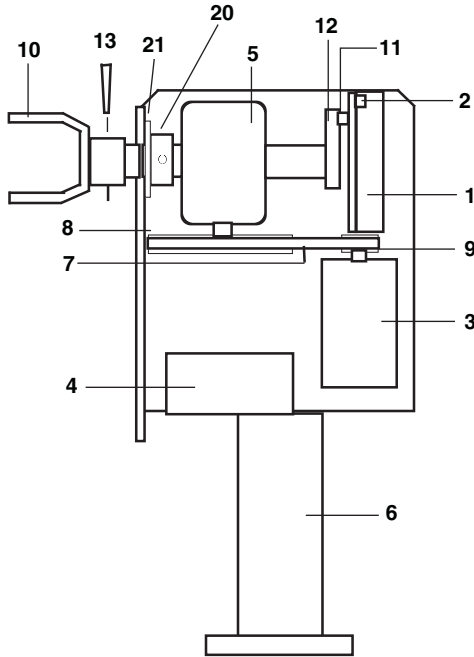

NOTE: Mega Arm Tower not shown

PART NUMBERS AND DESCRIPTIONS

ITEM	PART NUMBER	DESCRIPTION
1	MA001	Controller
2	MA002	Removable Connector
3	MA003	DC Motor - 24 Vdc
4	MBAT	12Vdc 7AH Battery 2 required
5	MA005	Gear Reducer 60:1
6	MA006	Aluminum Chassis
7	MA007	Drive Belt
8	MA008	Reducer Pulley
9	MA009	Motor Pulley
10	MA010	Gate Arm Bracket
11	MA011	Magnet
12	MA012	Cam Arm
13	MA013	Shear Pin

ITEM	PART NUMBER	DESCRIPTION
14	MA014	Bolt and Nut (4) Motor
15	MA015	Transformer
16	MA016	120 Vac Duplex Outlet (120 Vac Only)
17	MA017	Bolt and Nut (4) Reducer
19	MA019	On/Off Switch
*	MA020	Unit Cover for Mega Arm (Not Tower)
*	MA021	Nylon Arm Nuts (2)
*	MA022	Arm Bolts (2)
*	MA023	Gate Arm - 12'
*	73A3	Filter Module
*	74-31243	Surge Suppressor
20	MA036	Collar
21	MA037	Nylon Washer

(*) parts not shown

PARTS SHIPPED

ITEM	QTY
MEGA ARM Operator	1
Controller	1
Unit Cover	1
Installation and Service Manual	1
Arm Bolts with Washers	2
Nylon Nuts	10
7AH Batteries	2

MEGA ARM TOWER UNIQUE PARTS LIST

ITEM	PART NUMBER	DESCRIPTION
*	MA020T	Unit Cover for Mega Arm Tower
*	MA020D	Unit Door for Mega Arm Tower

MEGA ARM OPTIONS PARTS LIST

ITEM	PART NUMBER	DESCRIPTION
*	71-TRAP	Trap option
*	71-SPRINT	Sprint option
*	71-TRAPSP	Sprint Trap option

ACCESSORIES FOR DC BARRIER ARM OPERATORS

371LM

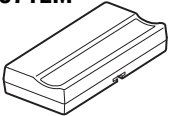

SECURITY+® Single Button Remote Control:
Includes visor clip.

373LM

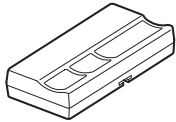

SECURITY+® 3-Button Remote Control:
Includes visor clip.

374LM



SECURITY+® 4-Button Remote Control:
Includes visor clip.

CPT13

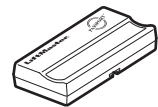

Passport™ 1-Button Remote Control:
Includes visor clip.

CPT33



Passport™ 3-Button Remote Control:
Includes visor clip.

CPT43



Passport™ 4-Button Remote Control:
Includes visor clip.

A24

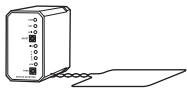

24Vdc Loop Detector

A57

Wiring Harness: For the A24.

MA201

Heater Kit: 150 watt with thermostat (MA and MAS only).

UN201

Heater Kit: 500 watt with thermostat (MAT and MATS only).

MA005C

Slip Clutch Option: For Mega Arm Gear Box.

MA200

K1 Relay Output Option

Sprint Units Only:

SP8

Sprint Gate Arm: 8' Padded Safety Arm, yellow.

SP8 TUBE

Replacement Arm Tube

SP8 PAD

Replacement Pad: Yellow.

MA023

Aluminum Arm: White, 12' x 3" diameter with warning labels.

MA024

Aluminum Arm: 12' x 3" diameter with yellow/black stripes.

MA024R (Highly Recommended)

Aluminum Arm: 12' x 3" diameter with reflective yellow/black stripes.

MA021

Nylon Arm Nuts: (Pkg. of 50).

MA021A

Nylon Arm Nuts: (Pkg. of 50), thin.

MA031

Adapter Collars: For padded arm option (2 included).

MA025

Round Padded Arm: 12' x 4" diameter, yellow (requires MA031).

MA026

Replacement Pad: 12' x 4" diameter, yellow.

MA027

Replacement Arm Tube: 12' x 2" diameter.

MA028

Round Padded Arm: 14' x 4" diameter, yellow (requires MA031).

MA029

Replacement Pad: 14' x 4", yellow.

MA030

Replacement Arm Tube: 14' x 4".

MA117

Counter Weight: Required for all 15' arms.

MA115

Aluminum Gate Arm: White, 15' x 3" (requires MA117).

MA116

Aluminum Gate Arm: 15' x 3" with yellow/black stripes (requires MA117).

MA116R

Aluminum Gate Arm: 15' x 3" with reflective yellow/black stripes (requires MA117).

MA034 (Highly Recommended)

Articulating PVC (folding) Arm: 9' with hardware kit.

MA033

Hardware Kit: (Only for MA034).

MA035

PVC Arm: 9' (Only for MA034).

MA024-10

Articulation Aluminum (folding) Arm: 10' without hardware kit, with yellow/black stripes.

SAMSKIT

Includes required relay and limits.

MA230VKIT

Includes surge suppressor, wire jumper, duplex box covers and detailed instructions.

WARRANTY POLICY

(You must read, understand and agree with all items in the limited warranty)

LiftMaster warrants the **MEGA ARM-UL** to be free of defects in workmanship and materials for a period of 2 years for electronics and mechanical components and includes a 10 year corrosion perforation warranty on the cover and chassis. Warranty will begin from the date of purchase.

LiftMaster reserves the right of final determination as to the existence and causes of any defect or failure. Any part or parts found to be defective and are returned to LiftMaster within the warranty period, shall at our option be repaired or replaced free of charge F.O.B. the factory. Freight is not included at any time on gate arms and chassis. ONLY UPS ground freight is included during the first year of warranty.

The warranty will not apply the following circumstances which are considered beyond our control.

Mis-use, vandalism, accident, neglect, unauthorized repairs or modifications, acts of God (lightning, floods, insect damage, etc.), power surges, units subjected to corrosive environments, incorrect installation or application, the batteries or incorrect battery installation, operation without or failure to use correct battery type, damage to arm bracket and/or gear reducer due to use of incorrect arm.

The warranty set forth above is entirely exclusive and no other warranty whether written or oral, is expressed or implied. LiftMaster specifically disclaims any and all implied warranties, merchantability or fitness for a particular purpose. It is the purchasers sole and exclusive responsibility to determine whether or not the equipment will be suitable for a particular purpose. In no event shall LiftMaster, inc. be held liable for direct, indirect, incidental, special, consequential damages or loss of profits whether based on contract, tort, or any other legal theory during the course of the warranty or at any time there after. The installer and/or end user agree to assume all responsibility for all liability in use of this product, releasing LiftMaster of all liability.

WARNING! MEGA ARM NOT FOR USE WITH BICYCLES OR PEDESTRIANS. YOU MUST PROVIDE APPROPRIATE SIGNAGE BEFORE ACTIVATING THE UNIT. NEVER ALLOW CHILDREN TO PLAY NEAR OR OPERATE AUTOMATIC GATES.

IN ORDER TO INSTALL AND USE THE MEGA ARM, YOU MUST UNDERSTAND AND BE IN FULL UNCONDITIONAL AGREEMENT WITH ALL STIPULATIONS OUTLINED ABOVE. IF YOU ARE NOT IN FULL AGREEMENT, DO NOT PUT UNIT INTO OPERATION. IF OPERATOR IS PUT INTO OPERATION THIS WILL BE CONFIRMATION THAT YOU ARE IN FULL UNCONDITIONAL AGREEMENT WITH ALL OF THE ABOVE STIPULATIONS.

Materials, components, features and specifications are subject to change without notice.

WARRANTY REGISTRATION

MAIL OR FAX THIS PORTION TO LIFTMASTER TO CONFIRM YOUR WARRANTY

NAME OF INSTALLING DEALER _____

NAME OF CUSTOMER _____

ADDRESS _____

CITY _____ STATE _____ ZIP CODE _____

MODEL _____ SERIAL NUMBER _____

EXPECTED CYCLES PER DAY _____

NUMBER OF HOMES OR APARTMENTS _____

CONFIGURED AS A(N) 1) VISITOR ENTRANCE _____

2) RESIDENT ENTRANCE _____

3) MAIN ENTRANCE _____

4) EXIT _____

5) OTHER (EXPLAIN) _____

REPAIR PARTS AND SERVICE

HOW TO ORDER REPAIR PARTS

OUR LARGE SERVICE ORGANIZATION
SPANS AMERICA

INSTALLATION AND SERVICE INFORMATION
SIMPLY DIAL OUR TOLL FREE NUMBER:

1-800-528-2806

www.liftmaster.com

WHEN ORDERING REPAIR PARTS, ALWAYS GIVE THE
FOLLOWING INFORMATION:

- PART NUMBER
- PART NAME
- MODEL NUMBER

ADDRESS ORDERS TO:
THE CHAMBERLAIN GROUP, INC.
Technical Support Group
6050 S. Country Club Road
Tucson, Arizona 85706