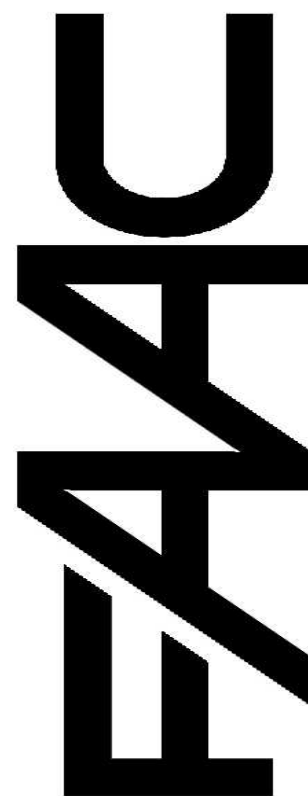

THE 415 L LS OPERATOR AND 455 D CONTROL PANEL: INSTALLATION MANUAL

May, 2006
415 L LS Operator And
455 D Control Panel
Installation Manual

CONTENTS

Important Safety Information	2
Technical Data	4
Unpacking the Operator	5
The 415 L LS Operator General Characteristics	6
Installation Instructions	6
Prepare the Gate	6
Manual Release Mechanism	6
Install the Operator	7
Install the 455 D Control Panel	10
Exploded View, 415 L LS	12
415 L LS Parts List	13
The 455 D Control Panel Installation Instructions	
The 455 D Control Panel General Description	14
Installing the 455 D Control Panel	14
Connect the Main Power Supply	14
Connect the Operator to the Control Panel	15
Check the Motor's Direction of Rotation	15
Connect Other Devices	16
Set Other Operating Controls	18
Programming	20
Learning of Operating Times	22
Learning of Normal Times	22
Learning Times with Limit Switches	23
Automated Systems Test	23
Logic Tables of 455 D Control Panel	24
Maintenance	26
Safety in Gate Design	26
Troubleshooting	27
Limited Warranty	28

The logo for FAAC, consisting of the letters 'F', 'A', 'A', and 'C' stacked vertically in a bold, stylized, sans-serif font.

FAAC International, Inc.
303 Lexington Avenue
Cheyenne, WY 82007
www.faacusa.com

IMPORTANT SAFETY INFORMATION

Both the installer and the owner and/or operator of this system need to read and understand this installation manual and the safety instructions supplied with other components of the gate system. This information should be retained by the owner and/or operator of the gate.

WARNING! To reduce the risk of injury or death

1. **READ AND FOLLOW ALL INSTRUCTIONS.**
2. Never let children operate or play with gate controls. Keep the remote control away from children.
3. Always keep people and objects away from the gate. **NO ONE SHOULD CROSS THE PATH OF THE MOVING GATE.**
4. Test the gate operator monthly. The gate **MUST** reverse on contact with a rigid object or stop when an object activates the non-contact sensors. After adjusting the force or the limit of travel, retest the gate operator. Failure to adjust and retest the gate operator properly can increase the risk of injury or death.
5. Use the emergency release only when the gate is not moving.
6. **KEEP GATES PROPERLY MAINTAINED.** Read the owner's manual. Have a qualified service person make repairs to gate hardware.
7. The entrance is for vehicles only. Pedestrians must use separate entrance.
8. **SAVE THESE INSTRUCTIONS.**

When installing the photo-beams supplied with this unit two things need to be considered.

1. Care should be exercised to reduce the risk of nuisance tripping, such as when a vehicle, trips the sensor while the gate is in motion.
2. One or more photobeams shall be located where the risk of entrapment exists, such as the perimeter reachable by the moving gate leaf.

GATE DESIGN

1. A gate is a potential traffic hazard, so it is important that you locate the gate far enough away from the road to eliminate the potential of traffic getting backed up. This distance is affected by the

size of the gate, how often it is used, and how fast the gate operates.

2. The operator you choose to install on your gate must be designed for the type and size of your gate and for the frequency with which you use the operator.
3. Your gate must be properly installed and must work freely in both directions before the automatic operator is installed.
4. An automatic operator should be installed on the inside of the property/fence line. Do not install the operator on the public side of the property/fence line.
5. Pedestrians should not use a vehicular gate system. Prevent such inappropriate use by installing separate gates for pedestrians.
6. Exposed, reachable pinch points on a gate are potentially hazardous and must be eliminated or guarded.
7. Outward swinging gates with automatic operators should not open into a public area.
8. The operating controls for an automatic gate must be secured to prevent the unauthorized use of those controls.
9. The controls for an automatic gate should be located far enough from the gate so that a user cannot accidentally touch the gate when operating the controls.
10. An automatic gate operator should not be installed on a gate if people can reach or extend their arms or legs through the gate. Such gates should be guarded or screened to prevent such access.

INSTALLATION

1. If you have any question about the safety of the gate operating system, do not install this operator. Consult the operator manufacturer.
2. The condition of the gate structure itself directly affects the reliability and safety of the gate operator.
3. Only qualified personnel should install this equipment. Failure to meet this requirement could cause severe injury and/or death, for which the manufacturer cannot be held responsible.
4. The installer must provide a main power switch that meets all applicable safety regulations.
5. Clearly indicate on the gate with the 2 warning signs that are included (visible from either side of the gate).

6. It is extremely unsafe to compensate for a damaged gate by increasing hydraulic pressure.
7. Devices such as reversing edges and photobeams must be installed to provide better protection for personal property and pedestrians. Install reversing devices that are appropriate to the gate design and gate application.
8. Before applying electrical power, be sure that the voltage requirements of the equipment correspond to your supply voltage. Refer to the label on your operator system.

USE

1. Use this equipment only in the capacity for which it was designed. Any use other than that stated should be considered improper and therefore dangerous.
2. When using any electrical equipment, observe some fundamental rules:
 - Do not touch the equipment with damp or humid hands or feet.

- Do not install or operate the equipment with bare feet.
 - Do not allow small children or incapable persons to use the equipment.
3. If a gate system component malfunctions, turn off the main power before making any attempt to repair it.
 4. Do not attempt to impede the movement of the gate. You may injure yourself as a result.
 5. This equipment may reach high temperatures during operation; therefore, use caution when touching the external housing of the operator.
 6. Learn to use the manual release mechanism according to the procedures found in this installation manual.
 7. Before carrying out any cleaning or maintenance operations, disconnect the equipment from the electrical supply.
 8. To guarantee the efficiency of this equipment, the manufacturer recommends that qualified personnel periodically check and maintain the equipment.

U.L. CLASS AND FAAC OPERATOR

Model	Duty Cycle	Typical Use
Class I: Residential Vehicular Gate Operator		
400	620	<ul style="list-style-type: none"> • Home use • Small apartment building, for example, up to 4 units in a building, with limited public access
402	640	
412	750	
415	760	
422	885	
Class II: Commercial/General Access Vehicular Gate Operator		
400	640	<ul style="list-style-type: none"> • Apartment buildings • Very public access
620	885	
Class III: Industrial/Limited Access Vehicular Gate Operator		
400	640	<ul style="list-style-type: none"> • No public access
620	885	
Class IV: Restricted Access Vehicular Gate Operator		
620	640	<ul style="list-style-type: none"> • Prison rated security
885		

TECHNICAL DATA

THE 415 L LS OPERATOR

Parameter	Measure
Voltage required, VAC	115Vac
Duty type	Residential
Maximum duty cycle (cycles per hour)	25
Maximum leaf length, ft (m)	15 (4.5)
Maximum leaf swing, deg	110
Thrust and traction, ft-lb (Nm)	221 (300)
Stroke, in. (cm)	15 (38.1)
Rod speed, in./sec (cm/sec)	3/4 (1.85)
Operating Ambient Temperature Deg F (Deg C)	-4 thru +131 (-20 thru +55)
Operator dimensions, l ´ w ´ h, in. (mm)	37 x 4 x 6 (940 X 105 X 148)
Operator weight, lb (kg)	17.5 (8)
Current draw, (Amps)	2.5
Absorbed Power (Watts)	300
Maximum amperage draw for acces- sories, mA	.800mA

UNPACKING THE OPERATOR

When you receive your 415 L LS Operator, complete the following steps.

Inspect the shipping box for physical damage such as a torn carton. Then inspect the operator after you remove it from the box. Notify the carrier immediately if you note any damage because the carrier must witness the damage before you can file a claim.

As you unpack the box, insure that all the parts listed below are included (See Figure 1).

- (1) Control panel enclosure with control panel.
- (1) 415 L LS Operator.
- (1) 4 Conductor Electric Cable for Motor Connection
- (1) 3 Conductor Electric Cable for Limit Switch

Connection

- (1) Package of mounting hardware:
 - (1) Rear mounting brackets
 - (1) Rear mounting plates that attach to the gate post (or column)
 - (1) Front mounting brackets that attach the operators to the gate leaves
- (1) Parts package:
 - (2) Manual Release keys
 - (4) Snap rings
 - (1) Long pins for rear mounting (each requires 2 snap ring)
 - (1) Short pins for front mounting (each requires 2 snap rings)
 - (1) Cable Cover
 - (2) Cable Strain Reliefs

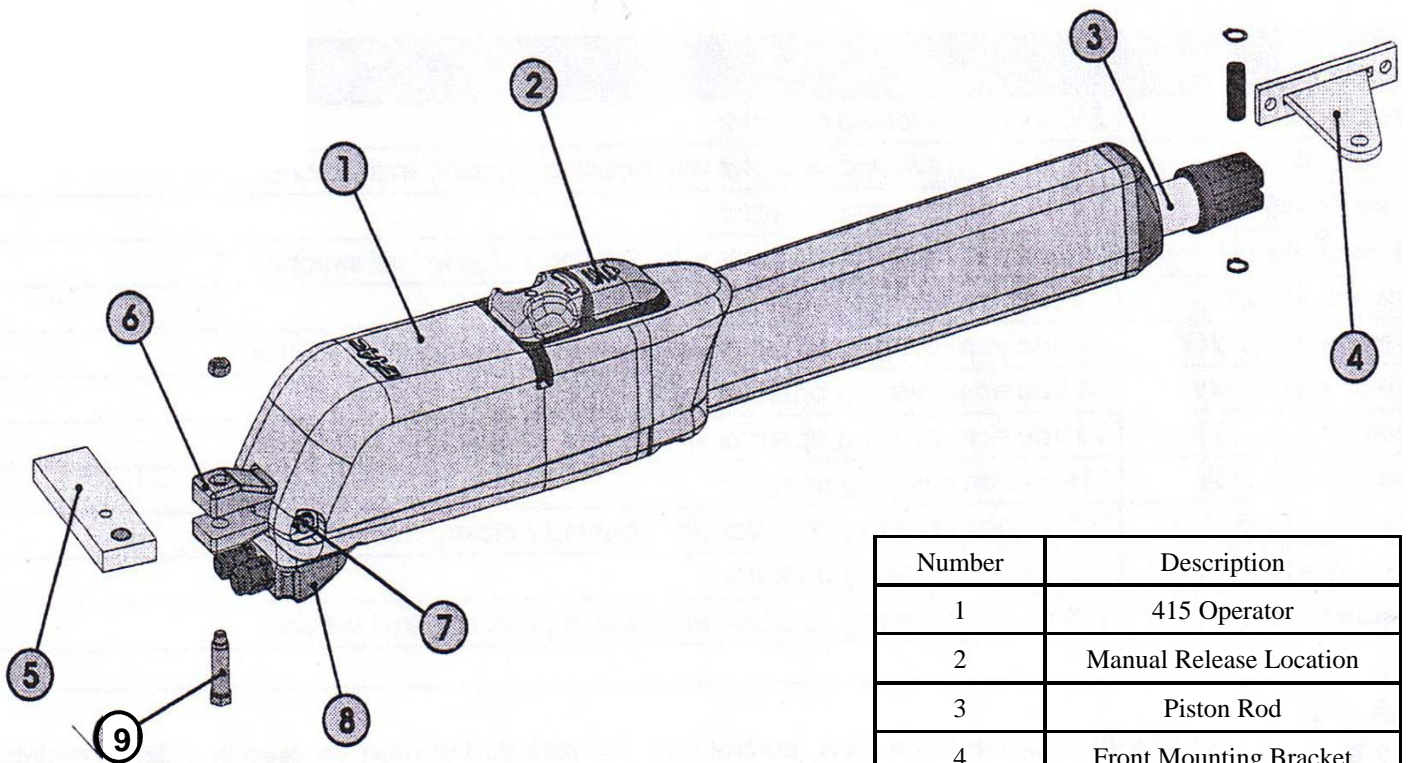

Figure 1. Parts of the 415 L LS Operator

Number	Description
1	415 Operator
2	Manual Release Location
3	Piston Rod
4	Front Mounting Bracket
5	Rear Mounting Bracket
6	Rear Fork
7	Long Rear Pin
8	Cable Cover
9	Short Rear Pin

THE 415 COMPACT OPERATOR

GENERAL CHARACTERISTICS

The FAAC 415 L LS Operator is an automatic gate operator for a swinging gate leaf. The 415 L LS Operator is useful in residential applications and can accommodate a gate leaf up to 15 ft (4.5 m) long.

The self-contained 415 L LS Operator consists of an electric motor that drives a worm screw housed in an aluminum casing.

The locking the 415 L LS Operator provides in the fully opened and fully closed positions is a service device rather than a security device. Additional, external locks are recommended under the following conditions:

- * It is a solid-faced gate.
- * The installation requires tight security.
- * The site is subject to vandalism.
- * The site is subject to strong or very gusty wind

In two-operator gate installations, both (master/slave) operators are wired to one control panel.

The electronic control panel is a microprocessor-based controller that accepts a wide range of product accessories and reversing devices, thus allowing for flexible gate system design.

Also for the protection and proper operation of the 415 L LS Operator, each operator has built in limit switches.

Built-in security and anti-crushing measures of the 415 L

LS Operator include a torque adjustment that controls the force transmitted to the gate leaf through the 415 L LS Operator.

The Manual Release mechanism is a key accessed device that disengages (or engages) the cylinder on 415 L LS Operator. When the drive is disengaged, you can open and close the gate leaf by hand. Such manual operation of the gate is necessary during installation and useful during prolonged power failures.

The torque of the 415 L LS Operator is set during Basic Programming of the 455 D Control Panel. (see page 19 for Basic Programming).

Reversing devices (such as inductive loops and photocells) should be installed to provide non-contact reversing operation.

WARNING: To insure that the installation meets the UL 325 Standards. A set of photo beam (Part Number 785163) must be installed anywhere that an entrapment with the gate leaf(s) could happen.

During prolonged power outages the manual release may be used if needed.

NOTE: The limit switches can be used for two options.

- 1) **The limit switches can be used as positive stops. (basic learning)**
- 2) **The limit switches can be used as the point of slow down and positive stops are required. (complete learning)**

INSTALLATION INSTRUCTIONS

Installing the 415 L LS Operator involves preparing the gate, installing the operator(s), installing the control panel, programming control panel, and connecting other operational controls.

Note: The following installation instructions assume you are fully capable of installing an electromechanical operator on a gate. This manual does not instruct you in designing a gate, installing a gate (whether on masonry, wood, or metal posts), or basic electrical wiring. The installation tasks discussed in this manual are tasks particular to the 415 L LS Operator.

PREPARE THE GATE

Before you install the 415 L LS Operator, you need to prepare the gate itself for the operator. Be sure to do the following:

Make sure that the gate structure is solidly built. Add reinforcing crosspieces if necessary to the gate leaves. Make sure that the gate moves smoothly on its hinges without excessive friction by swinging it opened and closed by hand. If necessary, lubricate all the gate's moving parts.

Positive stops are not needed with the 415 L LS Operator due to built in limit switches.

MANUAL RELEASE MECHANISM

To manual release the 415 L LS Operator perform the following steps as shown in Figure 2.

1. Slide the key access cover toward the front of the operator.
2. Insert the key and turn it counterclockwise 1/4 turn.

3. Turn the manual release knob clockwise 1/2 turn.
4. To re-engage the operator, perform the procedure in reverse.

Now the 415 L LS Operator is manual released. You can move the gate freely.



Figure 2. Use the Manual Release key to disengage the 415 Operator from its motor so that you can move the gate leaf open and/or closed by hand.

ATTACH THE ELECTRIC CABLES

Before mounting the operator to the gate panel you must attach the two provided electric cables. See figure 3 & 4 for the detail sticker on the bottom of the operator.

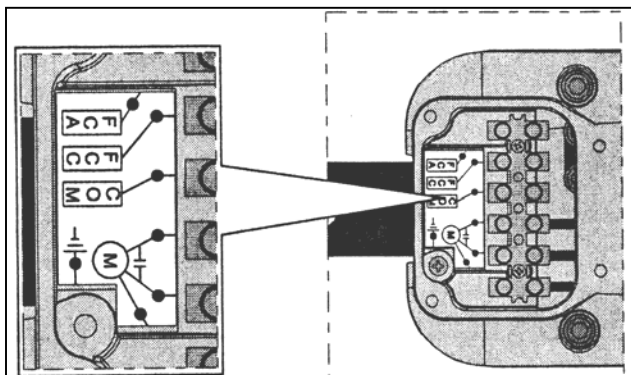

Figure 3. Electric Cable Detail Sticker

LIMIT SWITCH CABLE		
Sticker Labeled	Color	Description
COM	White	Common Wire
FCC	Red	Closing Limit
FCA	Black	Opening Limit
OPERATOR MOTOR CABLE		
Sticker Labeled	Color	Description
M	White	Common Wire
M	Red	Motor Directional
M	Black	Motor Directional
M	Yellow/Green (Green)	Earth Ground Only

Figure 4. Electric Cable Wire Color Codes

After attaching the electric cables to the 415 L LS Operator, you will need to thread the cables thru the assembled cable/strain relief cover and tighten the strain relief as shown in figure 5.

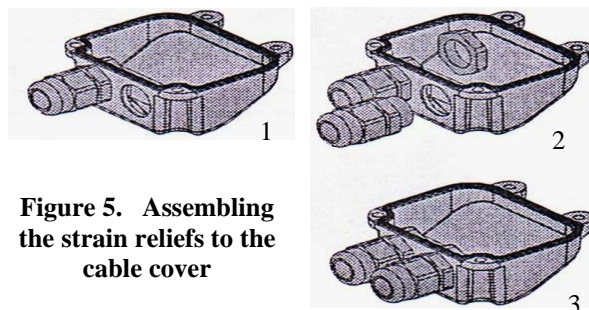

Figure 5. Assembling the strain reliefs to the cable cover

Slide the cable/strain relief cover up the cables until flush with the 415 L LS Operator and secure the cover with the four (4) screws provided as shown in figure 6.

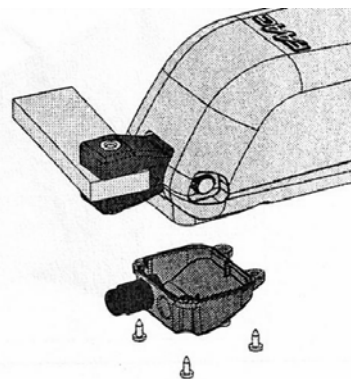

Figure 6. Attach the electric cable cover with two screws provided

INSTALLING THE OPERATOR

Once you have prepared the gate, you are ready to proceed with the installation of the operator.

Follow the instructions below to install your operator whether in an inward or outward swinging configuration.

Installing the operator consists of the following steps:

- * Attaching the rear mounting bracket
- * Attaching the operator to the rear mounting bracket
- * Attaching the front mounting bracket to the operator
- * Attaching the front mounting bracket to the gate leaf
- * Installing the 455 D control panel
- * Setting the operating controls

ATTACH THE REAR MOUNTING BRACKET

Inward swinging gate:

You need to determine whether to attach the rear mounting bracket directly to the post (or wall) or to notch the post and install a recessed liner. Large pillars require a recessed liner to house the rear mounting bracket and part of the operator so that the pillar will not interfere with the swing of the gate when it is fully opened.

To determine whether you need a recessed liner, measure the distances B and D (shown in Fig. 9) on your gate. If your measure of B or D is greater than the dimensions shown for your operator in Figure 9, notch the post and construct a recessed liner for the post mounting bracket (see Figure 7). The recessed liner should be constructed of 3/16 or 1/4 in. steel with a minimum interior height of 8in. (20.32 cm) so as to allow you to meet the required dimensions shown in Figure 9. Make sure the recessed liner is securely embedded in the post (or wall).

There are two parts to the rear mounting bracket. The horizontal bracket attaches to the operator, and the drilled plate that can be bolted to the gate post. Weld the two parts together and bolt the assembly to the gate post or column. Note, though, that use of the vertical rear mounting plate is optional.

Once you have positioned the rear mounting bracket, attach the bracket to the post (or wall or recessed liner), making sure the dimensions on your gate system match those shown in Figure 9.

Outward swinging gate:

If you are installing the 415 L LS Operator to swing the gate outward, construct a steel elbow of sufficient size to attach to the gate pillar and rear mounting bracket (see Figure 10 for elbow dimensions).

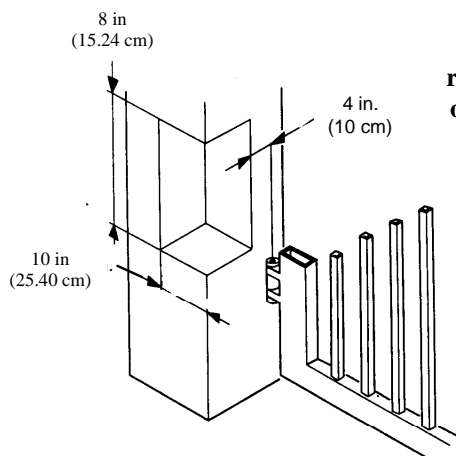

Figure 7. The required dimensions of the recessed liner when notching the gate post

ATTACH THE FRONT MOUNTING BRACKET TO THE GATE LEAF

Disengage the operator's manual release (see figure 2).

You should be able to lengthen or shorten the cylinder by pulling or pushing the cylinder. Lengthen or shorten the operator to the required distance for your gate installation:

Inward swinging: Lengthen the piston rod until the appropriate limit led (FCC or FCA) goes out on the control panel.

Outward swinging: Shorten the piston rod until the appropriate limit led (FCC or FCA) goes out on the control panel.

With the gate in the fully closed position, temporarily clamp the front mounting bracket (previously attached to the operator) to the gate leaf and insure that the cylinder is level.

Manually open the gate to ensure full swing of the operator.

Remove the operator from the front mounting bracket for welding.

With the operator detached from the front mounting bracket, permanently attach (weld or bolt) the front mounting bracket to the gate leaf (see Figure 8).

Once the front mounting bracket is welded or bolted in place, you can reattach the operator to the bracket.

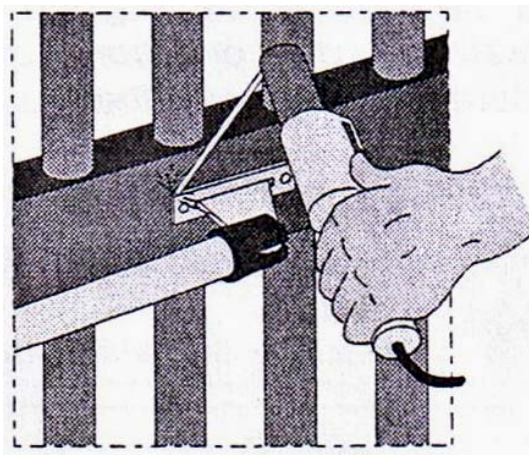

Figure 8. Weld the front mounting bracket into position after insuring the operator is level.

ATTACH THE OPERATOR TO THE REAR MOUNTING BRACKET

Attach the rear fork to the 415 L LS operator with the long steel pin and two "C" clips

Attach the operator to the rear mounting bracket with the short brass bolt and self locking nut.

ATTACH THE OPERATOR TO THE FRONT MOUNTING BRACKET

Attach the operator to the front mounting bracket with the short pin and one snap ring on the bottom and one snap ring on the top.

Figure 9. Important mounting dimensions for inward-swinging

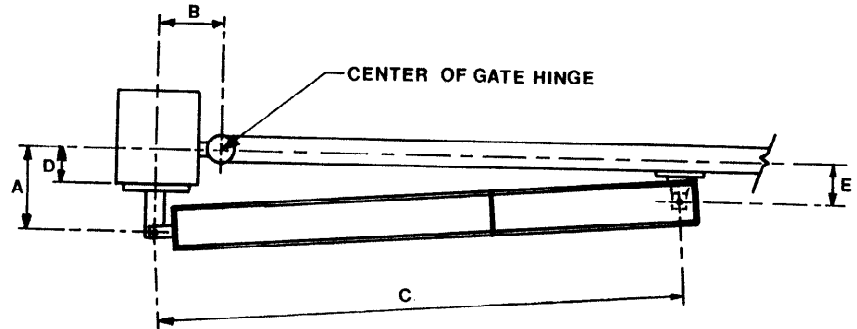

Mounting Dimensions		
	90-deg Swing	110-deg Swing
A	7 5/8 in. (195 mm)	6 5/8 in. (170 mm)
B	7 5/8 in. (195 mm)	6 5/8 in. (170 mm)
C	50 3/4 in. (1290 mm)	
D	Maximum 5 in. (125 mm)	4 2/5 in. (110 mm)
E	Less Than A	

Figure 10. Important mounting dimensions for outward-swinging 415 L LS operators, top view

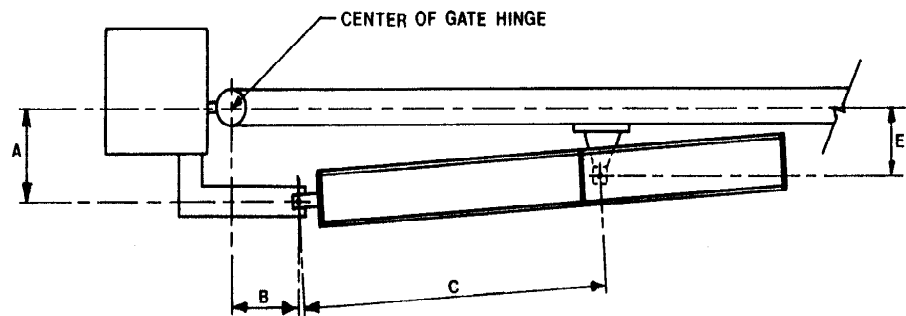

Mounting Dimensions		
	90-deg Swing	110-deg Swing
A	7 5/8 in. (195 mm)	6 5/8 in. (170 mm)
B	7 5/8 in. (195 mm)	6 5/8 in. (170 mm)
C	37 1/8 in. (943 mm)	
D	N/A	N/A
E	Less Than A	

ADJUSTING THE LIMIT SWITCHES

The limit switch adjustments are carried out as follows:

1. Unscrew the upper fastening screw, figure 11, ref. A, and remove the cap, figure 11, ref B.
2. To adjust the closing limit switch (FCC) turn the adjusting screw clockwise, figure 12, ref A, to increase the rod stroke, and counter-clockwise to reduce it.
3. To adjust the opening limit switch (FCA) turn the adjusting screw counter-clockwise figure 13 ref. A, to increase the rod stroke, and clockwise to reduce it.
4. Perform a couple of test cycles to check the correct position of the limit switch, if the limit switch adjustments need to be carried out again, repeat the operations starting from step 2.
5. Reattach the cap, figure 11, ref B, and tighten the fastening screw, figure 11, ref A.

WARNING! Motor one (1) limit switch must be wired to FCA1 and FCC1 on the 455 D Control Panel. Motor two (2) limit switch must be wired to FCA2 and FCC2 on the 455 D Control Panel.

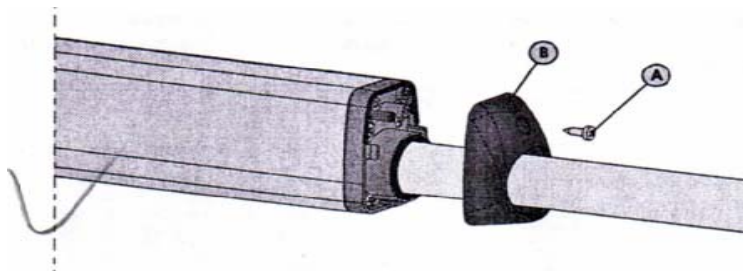

Figure 11.
Limit Switch Cover with Fastening Screw.

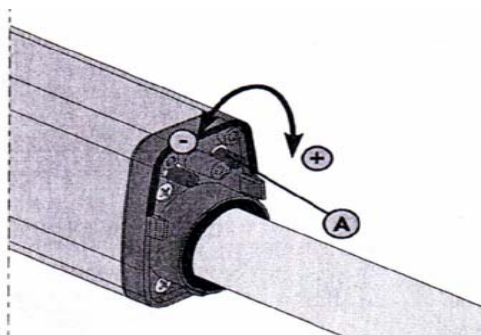

Figure 12.
Closing (FCC) Limit Switch Adjustment Screw

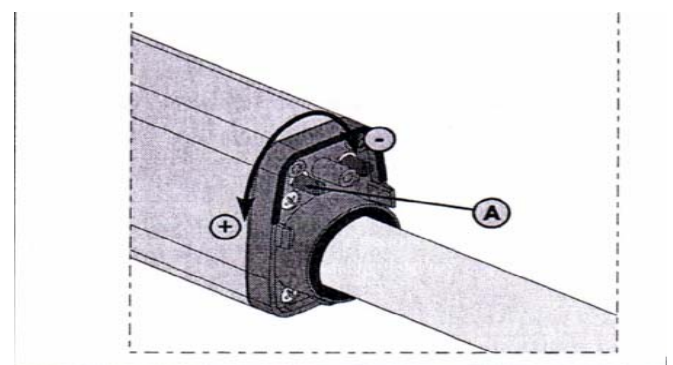

Figure 13.
Opening (FCA) Limit Switch Adjustment Screw

INSTALLING THE 455 D CONTROL PANEL

Locate the control panel in the most convenient position possible, considering the movement of the gate. Figure 14 shows a basic layout for a two-leaf gate with the 415 L LS Operator.

Installing the control panel consists of the following general steps:

- Connecting the main power to the control panel
- Connecting the activating device
- Connecting the operator to the control panel
- Checking the direction of the motor's rotation
- Connecting other devices to the control panel
- Set operating modes

The installer is responsible for grounding the gate and operator systems, for providing the main power breaker switch, and for making sure that the entire gate system meets all applicable electrical codes.

For the complete 455 D Control Panel Installation Instructions, see pages 14—25 of this manual.

Figure 14. The layout of a sample gate system

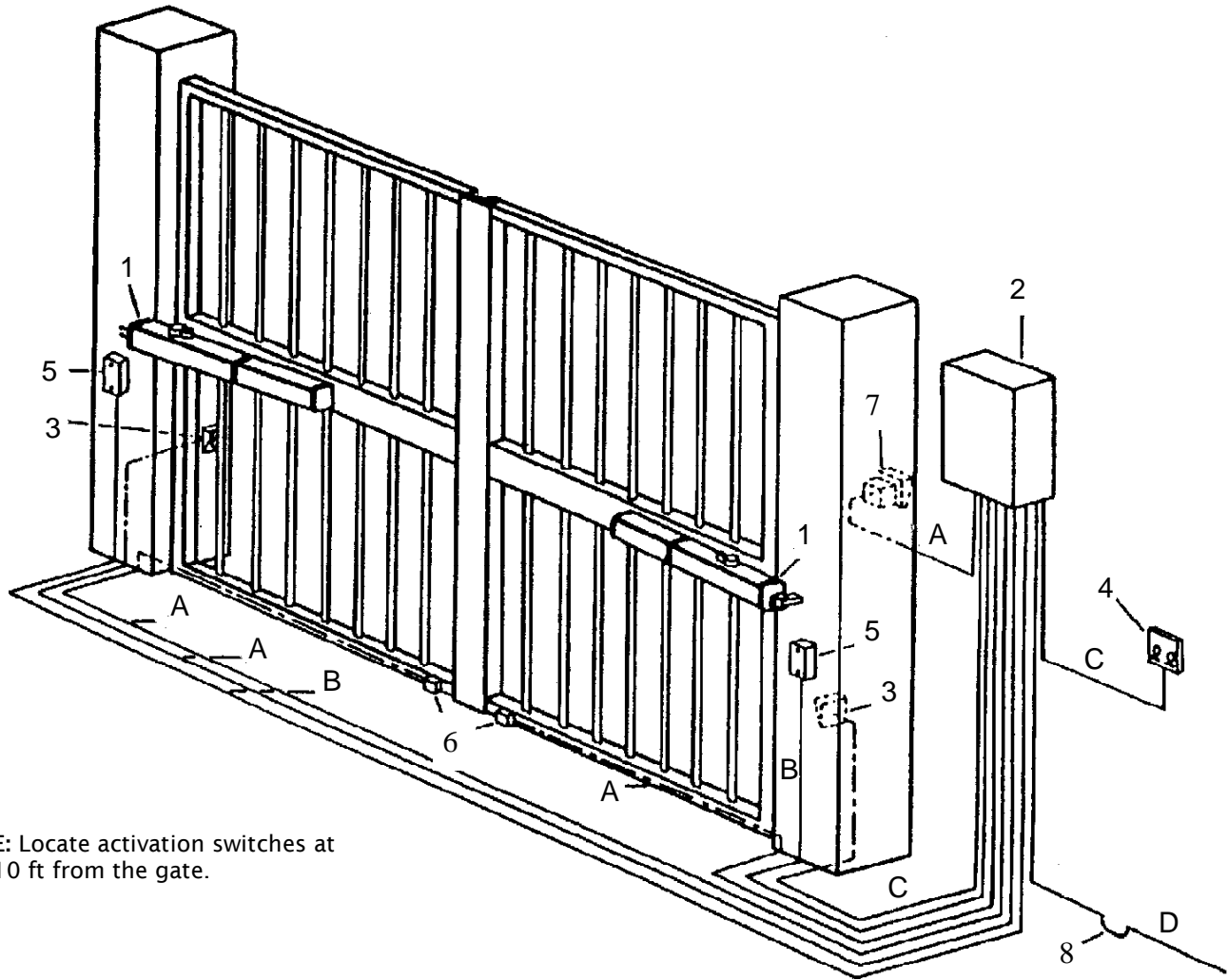

NOTE: Locate activation switches at least 10 ft from the gate.

1	Operator	Wire Gauges for Given Voltage	
		115 VAC	
2	Control Panel/Enclosure		
3	Photocell	A 2 × 18 AWG	A 2 × 18 AWG
4	Power Switch	B 4 × 14 AWG	B 4 × 14 AWG
5	FAAC 5 Wire Cable for Master/Slave Connection and a Junction Box	C 5 × 18 AWG	C 5 × 18 AWG
6	Gate stops	See Page 6 for further details on positive stop explanation	
7	FAAC Key Activated Switch (T10)	A 2 × 18 AWG	A 2 × 18 AWG
8	Wiring to main circuit breaker	D 2 × 12 AWG	

The 415 L LS Operator

415L LS

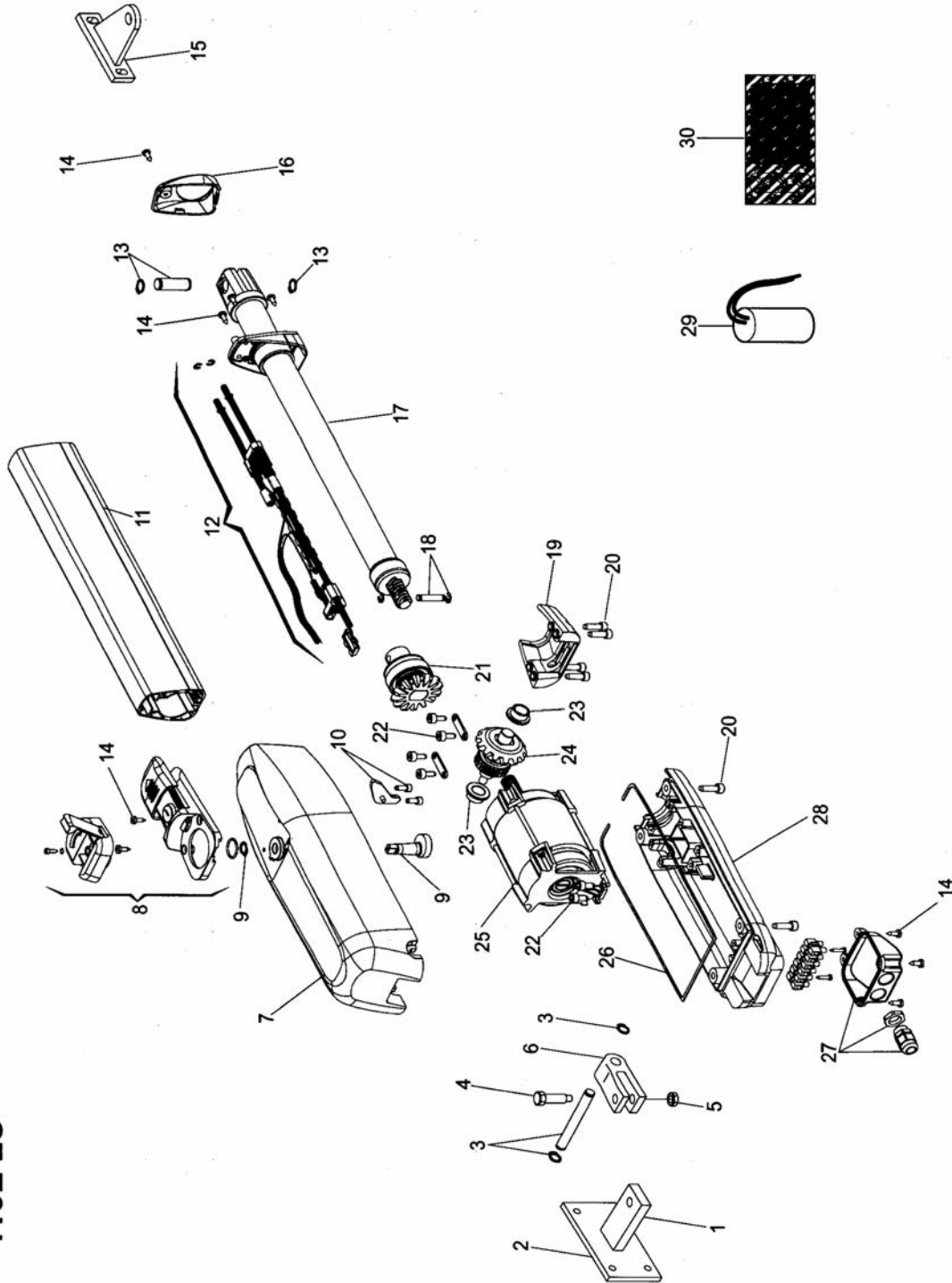

Parts List

415 L LS Operator

POS	PART NO.	DESCRIPTION	QTY
1	7220015	Rear Mounting Bracket	1
2	7284005	Rear Mounting Plate	1
3	718366	Long Pin with C Clips	1
4	7182075	Short Pin	1
5	N/A	Hex Nut	1
6	7221115	Rear Fork	1
7	716148	Rear Upper Body	1
8	428403	Manual Release Assembly	1
9	60202145	Snap Ring	1
10	60202155	Manual Release Lever	1
11	716150	Limit Switch Protective Cover	1
12	490108	Limit Switch Assembly	1
13	718354	Front Mounting Pin with C Clips	1
14	N/A	Self Tapping Screws 4.2 mm x 13 mm	7
15	728271	Front Mounting Bracket	1
16	711027	Limit Switch Adjusters Cover	1
17	490104	Cylinder	1
18	718367	Screw Drive Pin and C Clips	1
19	499399	Lower Front Cover	1
20	N/A	Self Tapping Screw 6.3 mm x 19 mm	8
21	60202225	Gear (Piston)	1
22	N/A	Self Tapping Screw 4.8 mm x 13 mm	10
23	60202165	Bushing	2
24	60202215	Gear (Motor)	1
25	770890	Motor 115Vac	1
26	709324	Gasket	1
27	60202175	Electric Cable Cover	
28	716149	Rear Body Lower Half	
29	2705	25µF Capacitor	1
30	490106	415 Skin Pack	

THE 455 D CONTROL PANEL

GENERAL DESCRIPTION

The FAAC 455 D control panel is used to operate the following models.

Swing gate operators:

400	415
402	750
422	760

Barrier gate operators:

615

The 455 D programming controls the following:

Operating logic: A, S, E, EP, B, AP and C logics available.

Reversing device behavior: Choose whether a triggered reversing device during closing immediately reverses gate movement or stops the gate and reverses gate movement when no longer triggered.

Torque or Pressure: Force adjustment for the 415 operator. Adjustable from 0 to 50.

Caution: For all hydraulic operators, the torque **must** be programmed to the maximum (50) setting.

Pause time between opening and closing: adjustable from 0 to 240 seconds.

Opening/Closing time: adjustable from 0 to 4 minutes. (Programmable)

Leaf delay on closing: adjustable from 0 to 4.1 minutes.

The 455 D control panel should be installed in an enclosure that is conveniently located as close as possible to the gate operator. All electrical connections from the control panel to the operator must be made in a weatherproof junction box.

The 455 D control panel requires a single-phase power supply voltage (115 VAC [$\pm 10\%$] or 230 VAC [$+6$ or -10%], 50-60 Hz). The power supply should be protected by a 15 amp dedicated circuit breaker (not provided).

The installer is responsible for grounding the operator system, for providing the main power

breaker switch, and for making sure that the entire gate system meets all applicable electrical codes.

NOTE: An installation is U.L. compliant only when you install the FAAC operators according to the UL325 standards.

INSTALLING THE 455 D CONTROL PANEL

Locate the control panel in the most convenient position possible, considering the movement of the gate.

Installing the control panel consists of the following general steps:

- * Connecting the main power to the control panel
- * Connecting the activating device
- * Connecting the operator to the control panel
- * Checking the direction of the motor's rotation
- * Connecting other devices to the control panel
- * Set operating modes

CONNECT THE MAIN POWER SUPPLY

WARNING! Turn the main power off before you make any electrical connections or before programming.

Wire the main power supply to control panel terminals in block J3 (see Figures 15 and 16). The installer is responsible for insuring that a separate, grounded circuit protected by a circuit breaker is between the control panel and the main power supply. All wiring should conform to applicable electrical codes, and all wiring and fittings should be weatherproof and/or suitable for burial.

Connect the ground to the grounding terminal in block J3 and connect the power wires to the terminals labeled N (neutral) and L (line).

NOTE: For a 230V system, a neutral is not needed. Connect one 115V line to the L (Line) and a second 115V line to the N (Neutral).

CONNECT THE OPERATOR(S) TO THE CONTROL PANEL

WARNING! Turn the main power off before you make any electrical connections or before programming.

CAUTION: The operators are grounded only by the grounded circuit the installer provides.

USING A JUNCTION BOX

If an operator is more than 2 ft away from the control panel, you must use a junction box for connection. Use a U. L. Listed cord grip(s) where the operator cord enters the junction box.

Note: If you have a one-leaf gate design, the operator **must** be connected to Motor 1 (terminals 1,2, & 3)

To wire up motor 1, connect the white wire to terminal 1(on the J4 terminal strip), the black wire to 2, and the red wire to 3. Wire each leg of the capacitor (supplied) to terminals 2 & 3.

Note: If you want to delay the closing of one gate leaf in a two-leaf gate design, be sure to connect its operator to Motor 1.

In order to wire motor 2 in a bi-parting system, connect the white wire to terminal 4 (on the J4 terminal strip), the black wire to 5, the red wire to 6. Wire each leg of the capacitor (supplied) to terminals 5 & 6.

CHECK THE MOTOR'S DIRECTION OF ROTATION

After you have connected the main power supply, and the operator(s) to the control panel, you need to check the direction of rotation for each operator motor in your gate design.

Note: To check a motor's direction of rotation, you must have three closed circuits on terminal block J1. Install one circuit between terminals 11 and 16, another circuit between terminals 12 and 19, and another circuit between terminals 13 and 19.

Figure 15. The 455 D Control Panel

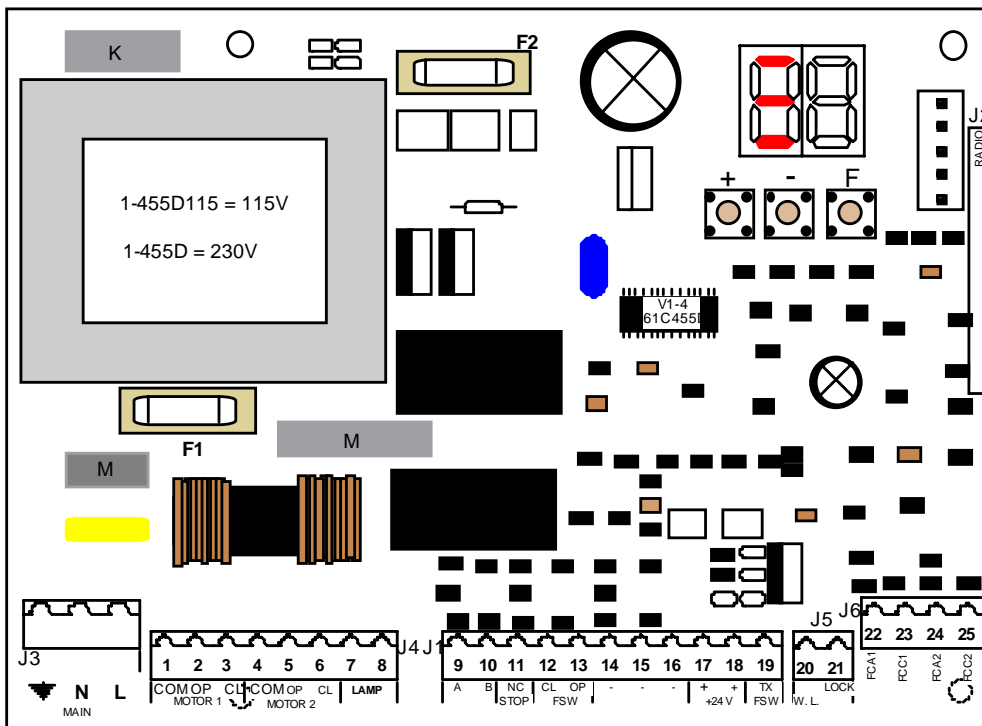

J3 terminal block for main power supply		
J4 terminal block for connecting the operator (s)		
J1 terminal block for low-voltage accessories		
J2 quick connector port		
F Function Push Button		
- Programming Push Button		
+ Programming Push Button		
FUSES	220 VAC	115 VAC
F1 Main Power	5 A	10 A
F2 Accessories	800 mA	800 mA

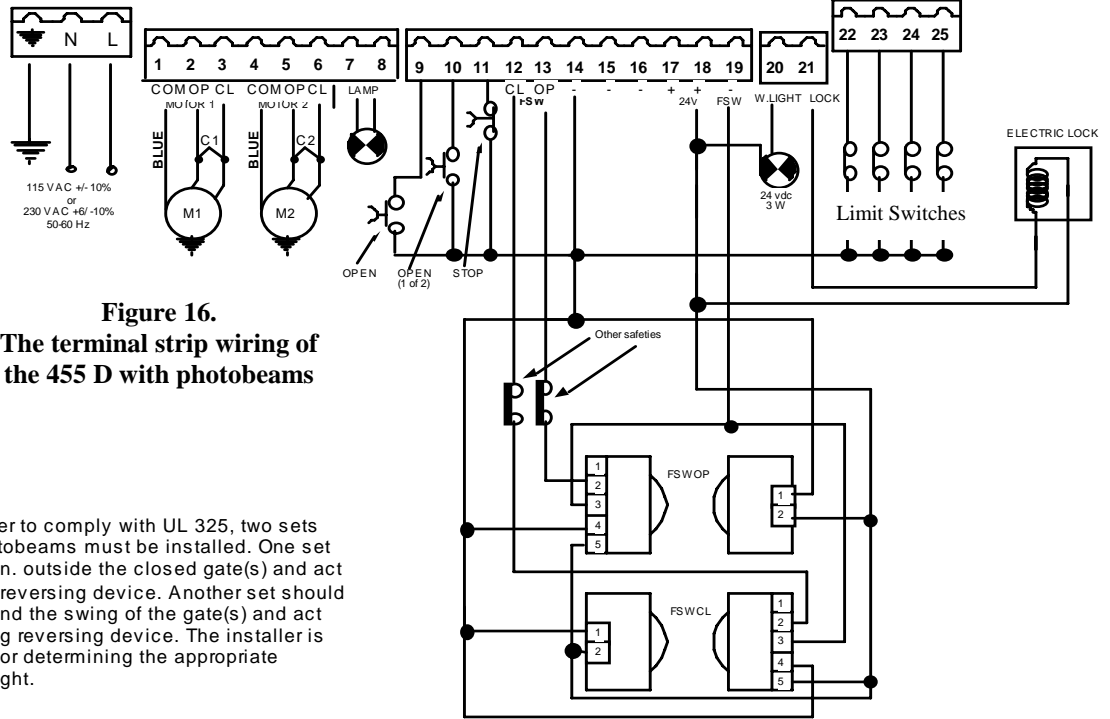

Figure 16.
The terminal strip wiring of the 455 D with photobeams

NOTE: In order to comply with UL 325, two sets of FAAC photobeams must be installed. One set should be 6 in. outside the closed gate(s) and act as a closing reversing device. Another set should be 6 in. beyond the swing of the gate(s) and act as an opening reversing device. The installer is responsible for determining the appropriate mounting height.

You cannot check the motor's direction of rotation without these circuits (jumpers) or the accessories. When properly prepared for testing, the LEDS FSWOP, STOP, and FSWCL should be illuminated (see figure 18 on page 17).

WARNING! Running the operator—even for testing purposes—without a connected reversing device is potentially dangerous. Do not place yourself within the path of the moving gate during your test.

Disengage the operator(s) with the Manual Release key (see operator installation manual), and open the gate by hand about halfway. Next, engage the operator(s) with the Manual Release key so that you can check the rotation of the motor (s).

To activate the operator(s) momentarily short across terminals 9 and 14.

Turn on the main power and send an activating signal to the operator. The gate leaf (or leaves) should open. If a gate leaf closes, then you need to turn off the main power and reverse the connection of the red and black wires on terminal block J4 for the operator controlling that leaf. Then you need to recheck the rotation direction again.

After having completed your test of the motor's direction of rotation, replace any test circuits you installed (between terminals 11 and 16, between 12 and 19, and between 13 and 19) with the proper reversing and stop devices. The instructions for installing such accessories follow.

CONNECT OTHER DEVICES

WARNING! Turn the main power off before you make any electrical connections.

POWER SUPPLY FOR ACCESSORIES: You can access a 24 VDC output for supplying power to accessories through terminals 17 or 18, (+) and 14 or 15 or 16, (-) on terminal block J1. In most cases, this source can be used to power 24 VDC accessories.

NOTE: The 455 D control panel allows a maximum accessory load of 800 mA.

REVERSING DEVICES: Reversing devices include photocells, inductive loops, and so forth. All of the reversing devices should have contacts of the normally closed (N.C.) type. Where you connect a device depends on whether you want the device to operate during opening or during closing.

NOTE: UL **does not** recognize the FAAC system with loop detectors or safety edges. FAAC photobeams must be used to comply with UL 325.

To wire photobeams, refer to page 19 (see FSWOP for opening photobeams, and FSWCL for closing photobeams). Photobeams must be connected as shown. See also page 19 for the wiring of inductive loops. If using more than one reversing device, they must be wired in series.

(a) To the U. L. Listed gate operator

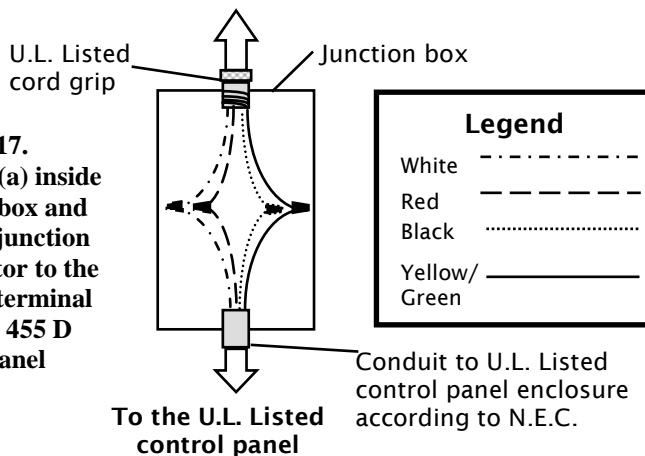
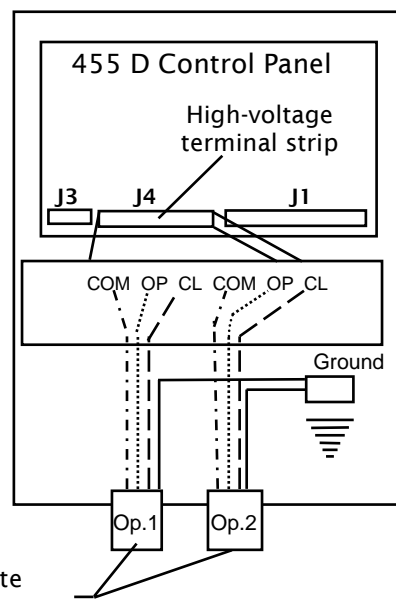

Figure 17.
 Wiring detail (a) inside
 the junction box and
 (b) from the junction
 box or operator to the
 high-voltage terminal
 strip on the 455 D
 control panel

(b) U.L. Listed Control Panel Enclosure



Cord grip or
 conduit from
 U.L. Listed gate
 operator(s)

ACTIVATING DEVICES AND RADIO RECEIVER: The activating devices and radio receiver for your gate must have normally open (N.O.) contacts. Connect such devices to terminals 9 and 14.

NOTE: The FAAC radio receiver plugs into the 5 prongs labeled J2 (Quick connect port).

Page 19 shows how to connect a three or four wire receiver.

DECODER CARD: If you are installing the Digicard magnetic card reader, or the Digikey keyboard, use the quick-fit connector J2 for the DS decoder card.

NOTE: If your using both a receiver and decoder, hard wire the decoder and plug in the receiver.

OPEN/HOLD OPEN DEVICE: To open and hold open the gate, simply maintain a contact across terminals 9 and 14. ("A" Mode only)

STOP BUTTON: The stop button you install must have normally closed (N.C.) contacts. Multiple stop buttons must be wired in series. Connect your stop device between terminals 11 and 16.

NOTE: The 455 D will not operate the motors without a closed circuit between 11 & 14.

The LED Indicators: The nine light emitting diodes (LEDs) on the control panel can be used to check for the proper function of the devices attached to the panel. The LED lights are on whenever the contacts are closed across each of the respective terminals.

OP_A and OP_B (Partial Opening) should illuminate only when an activating signal is sent for 2 and 1 gate leaves, respectively. STOP should be illuminated except when the stop button is pressed. FSWOP and FSWCL should be illuminated except when the reversing devices, for

LED	On	Off
OP_A	Command Given	No Command
OP_B	Command Given	No Command
Stop	No Command	Command Given
FSW Open	Opening reversing devices clear	Reversing device triggered
FSW Close	Closing reversing devices clear	Reversing device triggered
FCA1 FCC1	Flashes when gate coder is in use. Operator 1	
FCA 2 FCC 2	Flashes when gate coder is in use. Operator 2	

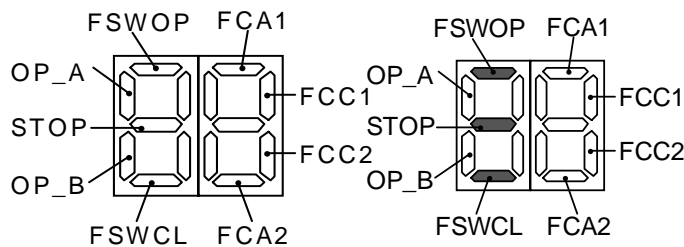

This display shows the
 meaning of each LED.

This display shows the normal
 status of the control panel.

Figure 18. The 455 D display.

opening and closing, respectively, are triggered. Use the LEDs and the next table to determine if the accessory devices you have installed are operating properly.

Electric Locks: An electric lock can be wired to the 455 D in terminals 18 and 21 (12Vac pulsed provided). If a reversing stroke is needed to allow the electric lock to release, this must be done in advanced programming.

See page 19 for the connections for a magnetic locking device.

WARNING LIGHT: Connect a warning light to terminals 18 and 20 in the group labeled *W.LIGHT* in terminal block J1 and J5. The terminals provide an output voltage of 24 VDC, maximum power 3 Watts. This output voltage will power most 24 VDC warning lights.

NOTE: The behavior of the warning light varies according to the logic you have set.

LOGICS A, S, E, EP, AP AND B: The warning light is on steadily during opening and the pause phase. During closing, the light flashes.

LOGIC C: The warning light is on steadily during opening and flashes during closing.

SET OTHER OPERATING CONTROLS

WARNING! Turn the main power off before you make any electrical connections.

You need to program the control panel for your gate's operation. The 455 D Control Panel has on board programming that controls a wide range of functions.

OPERATING LOGICS

NOTE: The 455 D Control Panel provides inputs for opening reversing devices and closing reversing devices. FAAC strongly recommends the use of reversing devices, such as photocells or other non-contact sensors.

- **A (automatic):** The gate opens on command and automatically closes after a pause phase. A second command while opening is ignored; a second command during the pause phase interrupts the pause time; a second command during closing reopens the gate. A maintained open command will hold the gate open.
- **S (security):** The security mode is like A logic except that a second command during opening immediately closes the gate. A maintained open command will not hold the gate open.

- **E (semi-automatic):** This mode requires a command to open and a command to close. A second command during opening stops the gate. A second command during closing reopens the gate.
- **EP (semi-automatic, step by step):** This mode requires a command to open and a command to close. A second command during opening or closing causes the gate to stop. A third command then reverses the previous motion of the gate.
- **B (manned, pulsed):** This mode is designed for guard station use and requires a three-button switch (pulsed) to open, close, and stop the gate.
- **C (manned and constant):** This mode requires constant pressure switches. One to open and one to close. No pressure on a switch stops the gate.
- **AP (stepped automatic):** The gate opens on command and automatically closes after a pause phase. A second command while opening is ignored; a second command during the pause phase interrupts the pause time; a second command during closing reopens the gate. A maintained open command will NOT hold the gate open.

The three programming push buttons allow the programming of the torque (or pressure), the pause time between opening and closing, and the leaf delay on closing.

WARNING! Turn the main power off before you make any electrical connections.

For all FAAC hydraulic operators using the 455 D control panel, the force **must** be set at its maximum setting of 50 in order to supply the correct voltage to the operator.

PAUSE TIME: The pause time between opening and closing can be adjusted from 0 seconds to 4 minutes. Time is adjusted in one-second increments from 0—59 seconds. When 60 seconds is reached, time is adjusted in 10 second increments up to 4 minutes. i.e. if display shows 2.5, it means 2 minutes and 50 seconds.

LEAF DELAY: You may choose to delay one leaf on closing for overlapping gate leaves. Be sure the operator on the leaf for delayed closing is connected to Motor 1. On opening, the leaf connected to Motor 2 is delayed 2.5 sec.

NOTE: If an opening leaf delay is desired, it must be enabled in the Advance Programming.

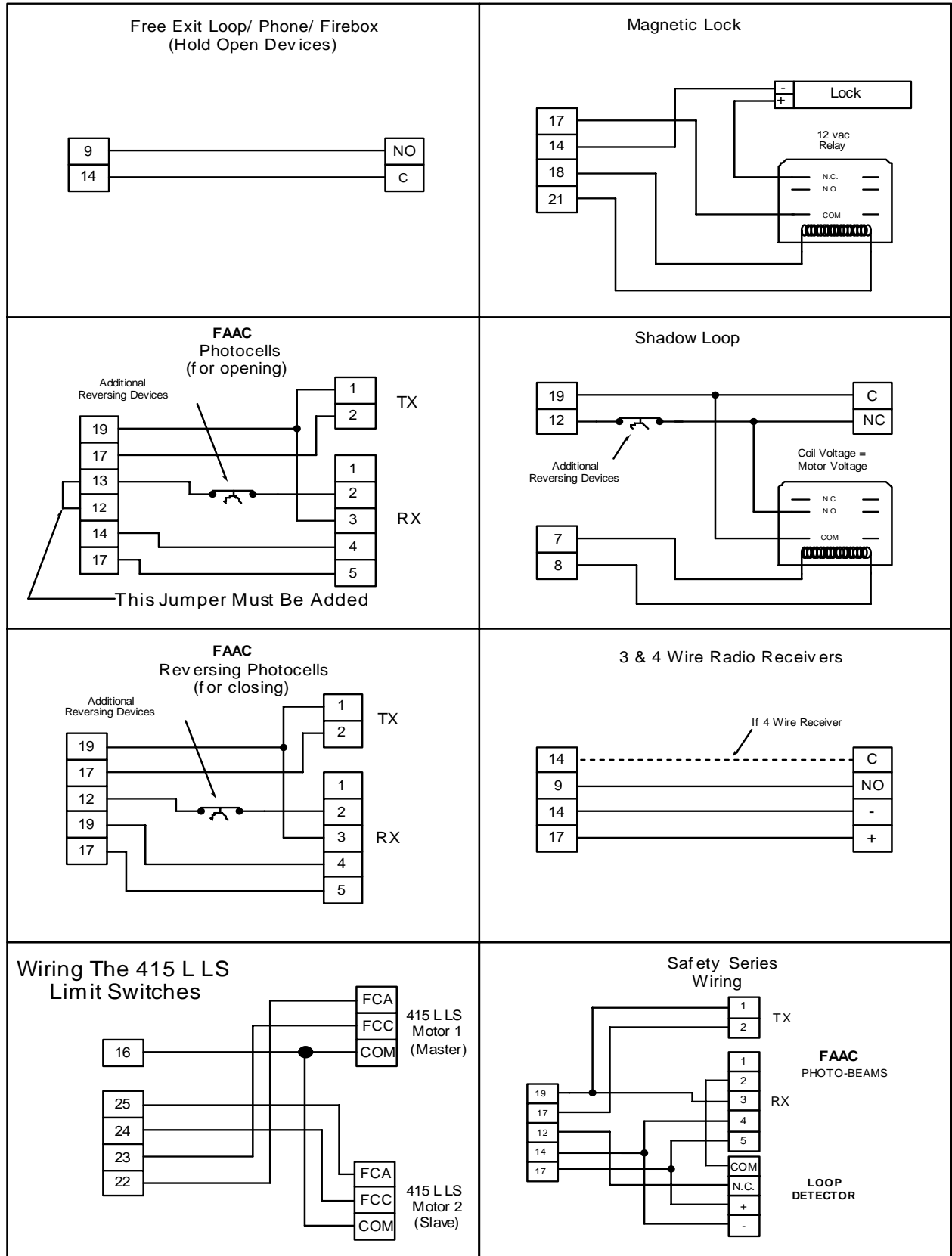

NO = Normally Open, NC = Normally Closed, C = Common, TX = Transmitter, RX = Receiver

Figure 19. Common Accessories wired to 455 D Control Panel

However, if enabled, you cannot *adjust* this opening delay of the operator connected to Motor 2.

The closing leaf-delay time is adjustable from 0 to 4 minutes.

NOTE: If the opening/closing time is set at less than the leaf delay time, the delayed leaf closes at the end of the closing time.

PROGRAMMING

To program the automated system, the "Programming Mode" must be accessed.

Programming is split into two parts: BASIC and ADVANCED.

RESTORE THE DEFAULT SETTINGS

To restore the default settings of the programming press the three program buttons (+, -, F) simultaneously and keep them pressed for five (5) seconds.



BASIC PROGRAMMING

To access BASIC PROGRAMMING, press the "F" key.

- If you press it (and hold it down), the display shows the name of the first function.
- If you release the key, the display shows the value of the function that can be modified with keys + and - .
- If you press and hold down the "F" key again (and hold it down), the display shows the name of the next function, etc.
- When you reach the last function, press "F" to exit the program, and the display resumes showing the status of the inputs.

The table on the right shows the sequence of functions accessible in BASIC PROGRAMMING.

PROGRAM BUTTONS		
+	-	F
LEFT	MIDDLE	RIGHT

BASIC PROGRAMMING		
		
Display	Function	Default
LO	OPERATING LOGICS A = Automatic (Timer to Close) E = Semi Automatic S = Security EP = (Semi-Automatic) Step by Step AP = Stepped Automatic B = Manned, Pulsed C = Manned, constant	E
PA	PAUSE TIME This is the time between open and closing and is adjustable from 0 to 4 min. This is only true in "A" Mode. (see pause time description)	0
F1	FORCE/TORQUE MOTOR 1 This adjusts the force / torque that motor 1 is applying to the gate leaf. Setting is 0 to 50.*	25
F2	FORCE/TORQUE MOTOR 2 This adjusts the force / torque that motor 2 is applying to the gate leaf. Setting is 0 to 50.*	25
cd	CLOSING LEAF DELAY Delays the closing of operator wired into motor one outputs. Adjustable from 0 to 4 minutes (Same as pause time)	0
LL	MOTOR RUN TIME This enables where you choose from "simple" learning or "complete" learning of the motor run time. See page 10 & 11 for complete details. Simple Learning  ≈ 1 s. Complete Learning  > 3 s.	
in	EXIT PROGRAMMING Exit from programming and return to display of inputs status.	

* With Hydraulic operators the Force/Torque must be set to the maximum setting of 50.

ADVANCED PROGRAMMING

To access ADVANCED PROGRAMMING, press the “F” key and, as you hold it down, press the “+” key:

- If you release the “+”, the display indicates the name of the first function.
- If you release the “F” key, too, the display shows the value of the function that can be modified with keys “+” and “-”.
- If you press the “F” key (and hold it down), the display shows the name of the next function, and if you release it, the value that can be modified with keys “+” and “-”.
- When you reach the last function, press the “F” key to exit the program, and the display resumes showing the status of the inputs.

The table on page 21 and 22 shows the sequence of functions accessible in ADVANCED PROGRAMMING.

ADVANCED PROGRAMMING		
Display	Function	Default
60	MAXIMUM TORQUE AT INITIAL THRUST: The motors operate at maximum torque (ignoring the torque setting) at start of movement. Useful for heavy leaves. Y = Enable No = Disabled	no
25	LAST STROKE AT CLOSING: The motors are activated at full speed for 1s to facilitate locking of the electric lock. Y = Enable No = Disabled	no
75	REVERSING STROKE: Before opening, while the gate is closed, the motors thrust to close for 2 s thus facilitating release of the electric lock. Y = Enable No = Disabled	no
00	LEAF 2 OPENING DELAY (2s): Enables delayed start (at opening) of leaf 2, avoiding interference between leaves. Y = Enable No = Disabled	no

Display	Function	Default
FS	FAIL SAFE: If this function is activated, it enables a function test of the photocells before any gate movement. If the test fails (photocells not serviceable), the gate does not start the movement. Y = Enable No = Disabled	no
PF	PRE FLASHING (5s): Activates the flashing lamp for 5s before start of movement. Y = Enable No = Disabled	no
EL	ELECTRIC LOCK ON LEAF 2: For using the electric lock on leaf 2 instead of on leaf 1. Y = Enable No = Disabled	no
50	INDICATOR-LIGHT: If 0 is selected, the output functions as a standard indicator-light (lighted at opening and pause, flashing at closing, and off when gate closed). Different figures correspond to timed activation of the output, which can be used (via a relay) to power a courtesy lamp. Time can be adjusted from 0 to 59s in 1s increments, and from 1.0 to 4.1 min. in 10s steps. 0 = Standard Indicator-Light From 1 to 4.1 = Timed Output	00
Ph	CLOSING PHOTOCELLS REVERSE AT RELEASE: Enable this function if you want the closing photocells to stop the gate movement and reverse it after the beam is cleared. Default setting is immediate reverse. Y = Enable No = Disabled	no
Ad	A.D.M.A.P. FUNCTION: If this function is enabled, the safety devices operate in compliance with French standard NFP 25/362. Y = Enable No = Disabled	no

ADVANCED PROGRAMMING CONTINUED		
Display	Function	Default
85	<p>ASSISTANCE REQUEST (COMBINED WITH NEXT FUNCTION): If activated, at the end of countdown (settable with the next function, i.e. "Cycle programming") it effects 8s of pre-flashing at every Open pulse (job request). Can be useful for setting scheduled maintenance jobs.</p> <p>Y = Enable No = Disabled</p>	no
21	<p>CYCLE PROGRAMMING: For setting count down of system operation cycles. Settable (in thousands) from 0 to 99 thousand cycles. The displayed value is updated as cycles proceed. This function can be used to check use of the board or to exploit the "Assistance Request" function.</p>	0
E	<p>ANTI-CRUSHING SENSITIVITY: When operating with the gatecoder, it controls anti-crushing sensitivity.</p> <p>Y = Low No = High</p>	no
	<p>EXTRA WORK TIME: When operating without a gatecoder and limit-switch, if reversing occurs, and if the leaf does not reach its end contact point, you can activate this function to increase work time.</p> <p>Y = ACTIVE NO = DISABLED</p>	
h	<p>EXIT PROGRAMMING: Exit from programming and return to display of inputs status.</p>	

LEARNING OF OPERATING TIMES

WARNING: During the learning procedure, the safety devices are disabled! Therefore, any and all traffic must be avoided in the path of the gate leaf (s).

NOTE: Programming must start with the gate(s) in the closed position.

Opening/closing time is established by the learning procedure which varies slightly according to whether you are or are not using Gatecoders.

LEARNING OF NORMAL TIMES

Normal learning (i.e. without Gatecoders) can be done in two different ways:

SIMPLE LEARNING (WITHOUT SLOW DOWN)

Close the gates, enter "BASIC PROGRAMMING", select the TIME LEARNING function and press the + push-button for 1 second the display begins flashing and the leaves begin the opening movement.

Wait for the leaves to reach the opening positive stop and then supply an OPEN A command after the desired motor run time has been reached (by push-button or radio control) to stop the movement: the leaves stop and the display stops flashing. One more command given will close the gate.

The procedure has ended and the gate is ready to operate.

COMPLETE LEARNING (WITH SLOW DOWN)

NOTES:

- If you do not wish to slow the gate operator (s) down, wait for the gate to reach its positive stop and supply two (2) consecutive open commands (within 1 second).
- If only one gate operator (1) is used, you must go through the entire programming procedure, as if you were programming for two gate operators (2). When the operator has finished opening, supply 5 open commands until the gate operator begins to close, and then resume normal operations.

Close the gates, enter "BASIC PROGRAMMING", select the TIME LEARNING function and press the + push-button for more than 3 seconds: the display begins flashing and leaf 1 begins opening. The following functions can be commanded by the OPEN A (by push-button wired to terminals 9 and 14, or radio control):

- When gate operator (1) reaches the position that you want it to slow down, an open command must be given to start the slow down phase.
- When gate operator (1) reaches the positive stop and the desired motor run time has been reached, an open command must be given to shut the motor off. At this point gate operator (2) will automatically start to open.
- When gate operator (2) reaches the position that you want it to slow down, an open command must be given to start the slow down phase.

- When gate operator (2) reaches the positive stop and the desired motor run time has been reached, an open command must be given to shut the motor off. At this point gate operator (2) will automatically start to close.
- When gate operator (2) reaches the position that you want it to slow down, an open command must be given to start the slow down phase.
- When gate operator (2) reaches the positive stop and the desired motor run time has been reached, an open command must be given to shut the motor off. At this point gate operator (1) will automatically start to close.
- When gate operator (1) reaches the position that you want it to slow down, an open command must be given to start the slow down phase.
- When gate operator (1) reaches the positive stop and the desired motor run time has been reached, an open command must be given to shut the motor off.

The display stops flashing and the gate is ready for normal operation.

LEARNING TIMES WITH LIMIT-SWITCHES

Learning with the Limit-Switches can be done in two different ways: One way (simple learning) *does not* require positive stops or (complete learning) *which does* require positive stops.

SIMPLE LEARNING (NO POSITIVE STOPS NEEDED)

Close the gates, enter "Basic Programming", select the TIME LEARNING function and press the + push-button for 1 second: the display begins flashing and the leaves begin the opening movement.

The movement stops automatically when the opening limit-switch(es) is reached and an activation is required to get the display stops flashing. Press the "F" button once more to exit programming, give the panel another "open" signal.

When the gate operator(s) reaches its limit-switch(es) time learning is complete.

COMPLETE LEARNING (POSITIVE STOPS NEEDED)

NOTES:

- If only one gate operator (1) is used, you must go through the entire programming procedure, as if you were programming a dual gate operating system is being installed (2). When the gate operator (1) has finished opening,

supply 5 open commands until the gate operator (1) begins to close, and then resume normal programming procedures.

Close the gates, enter "BASIC PROGRAMMING", select the TIME LEARNING function and press the + push-button for more than 3 seconds: the display begins flashing and leaf 1 begins opening movement. The following functions can be commanded by the OPEN A command (by radio control or key push-button):

- When gate operator (1) reaches the open limit-switch, it starts to slow down. When operator (1) reaches its positive stop an open command must be given to shut the motor off.
- When gate operator (1) reaches its positive stop and has shut off, gate operator (2) will automatically start to open
- When gate operator (2) reaches the open limit-switch, it starts to slow down. When operator (2) reaches its positive stop an open command must be given to shut the motor off.
- When operator's (2) motor shuts off it will automatically start to close.
- When gate operator (2) reaches the closed limit-switch, it starts to slow down. When operator (2) reaches its positive stop an open command must be given to shut the motor off.
- When operator (2) reaches its positive stops and the motor shuts off, gate operator (1) will start to close automatically.
- When gate operator (1) reaches the closed limit-switch, It starts to slow down. When operator (1) reaches its positive stop an open command must be given to shut the motor off.

The display will stop flashing. Press the "F" button one last time to return to the status display and the gate is ready for normal operation.

AUTOMATED SYSTEM TEST

When you have finished programming, check if the system is operating correctly.

Most important of all, check that the force is adequately adjusted and that the safety devices are operating correctly.

If pressure adjustments on hydraulic operators are not set before programming. It may need to be reprogrammed for desired results.

A (Automatic) Logic (455 D)

Gate Status	Open A	Open B	Stop	Opening Reversing Device(s)	Closing Reversing Device(s)	Warning Light
Closed	Opens both leaves and closes them after pause time	Opens single leaf connected to Motor 1 and closes it after pause time	No effect	No effect	No effect	Off
Opening	No effect	No effect	Stops	Stops; gate closes when reversing device no longer triggered	No effect	On
Opened	Interrupts the pause time	Interrupts the pause time	Stops	No effect	Gate remains open until reversing devices no longer triggered	On
Closing	Opens both leaves	Opens leaf	Stops	No effect	Reverses the gate immediately	Flashes
Stopped	Closes the leaves	Closes the leaf	No effect (opening is inhibited)	No effect	No effect (opening is inhibited)	On

S (Security) Logic (455 D)

Gate Status	Open A	Open B	Stop	Opening Reversing Device(s)	Closing Reversing Device(s)	Warning Light
Closed	Opens both leaves and closes them after pause time	Opens single leaf connected to Motor 1 and closes it after pause time	No effect	No effect	No effect	Off
Opening	Closes both leaves	Closes leaf	Stops	Stops; gate closes when reversing device no longer triggered	No effect	On
Opened	Closes both leaves	Closes leaf	Stops	No effect	Gate remains open until reversing devices no longer triggered	On
Closing	Opens both leave	Opens leaf	Stops	No effect	Reverses the gate immediately	Flashes
Stopped	Closes the leaves	Closes the leaf	No effect (opening is inhibited)	No effect	No effect (opening is inhibited)	On

B (Manned, Pulsed) Logic (455 D)

Gate Status	Open A	Open B	Stop	Opening Reversing Device(s)	Closing Reversing Device(s)	Warning Light
Closed	Opens 1 or both leaves	No effect	No effect	No effect	No effect	Off
Opening	No effect	No effect	Stops	No effect	Stops	On
Opened	No effect	Closes 1 or both leaves	No effect	No effect	No effect	On
Closing	No effect	No effect	Stops	Stops	No effect	Flashes
Stopped	Opens 1 or both leaves	Closes 1 or both leaves	No effect	No effect	No effect	On

E (Semi-automatic) Logic (455 D)

Gate Status	Open A	Open B	Stop	Opening Reversing Device(s)	Closing Reversing Device(s)	Warning Light
Closed	Opens both leaves	Opens single leaf connected to Motor 1	No effect	No effect	No effect	Off
Opening	Stops	Stops	Stops	Stops; gate closes when reversing device no longer triggered	No effect	On
Opened	Closes both leaves	Closes leaf	Stops	No effect	No effect (opening is inhibited)	On
Closing	Closes both leaves	Closes leaf	Stops	No effect (opening is inhibited)	Reverses the gate immediate	Flashes
Stopped	Closes the leaves	Closes the leaf	No effect (opening is inhibited)	No effect	No effect (opening is inhibited)	On

EP (Semi-automatic, Step by Step) Logic (455 D)

Gate Status	Open A	Open B	Stop	Opening Reversing Device(s)	Closing Reversing Device(s)	Warning Light
Closed	Opens both leaves	Opens single leaf connected to Motor 1	No effect (opening is inhibited)	No effect (opening is inhibited)	No effect (opening is inhibited)	Off
Opening	Stops	Stops	Stops	Stops; gate closes when reversing device no longer triggered	No effect	On
Opened	Closes both leaves	Closes leaf	Stops	No effect	No effect (opening is inhibited)	On
Closing	Stops	Stops	Stops	No effect (opening is inhibited)	Reverses the gate immediately	Flashes
Stopped	Gate leaves reverse direction	Gate leaf reverses direction	No effect (opening is inhibited)	No effect (opening is inhibited)	No effect (opening is inhibited)	On

C (Manned and Constant) Logic (455 D)

Gate Status	Open A	Open B	Stop	Opening Reversing Device(s)	Closing Reversing Devices(s)	Warning Light
Closed	Opens 1 or both leaves	No effect	No effect	No effect	No effect	Off
Opening	No effect	Stop	Stops	Stops	Stops	On
Opened	No effect	Closes 1 or both leaves	No effect	No effect	No effect	On
Closing	Stops	No effect	Stops	No effect	Stops	Flashes
Stopped	Opens 1 or both leaves	Closes 1 or both leaves	No effect	No effect	No effect	On

AP (Stepped Automatic) Logic (455D)

Gate Status	Open A	Open B	Stop	Opening Reversing Device(s)	Closing Reversing Devices(s)	Warning Light
Closed	Opens both leaves and closes them after pause time	Opens single leaf connected to Motor 1 and closes it after pause time	No effect	No effect	No effect	Off
Opening	Stops	Stops	Stops	Stops; gate closes when reversing device no longer triggered	No effect	On
Opened	Stops	Stops	Stops	No effect	Restarts the pause time	On
Closing	Opens both leaves	Opens leaf	Stops	No effect	Reverses the gate immediately	Flashes
Stopped	Closes the leaves	Closes the leaf	No effect (opening is inhibited)	No effect	No effect (opening is inhibited)	On

MAINTENANCE

THE 415 L LS OPERATOR

The FAAC 415 L LS Operator requires no maintenance. Periodically inspect the operator, however, to ensure continued proper operation.

THE 455 D CONTROL PANEL

Keep the Control Panel free from spider webs, insects, etc. Otherwise the Control Panel requires no maintenance.

SAFETY IN GATE DESIGN

- A gate is a potential traffic hazard, so it is important that you locate the gate far enough away from the road to eliminate the potential of traffic getting backed up. This distance is affected by the size of the gate, how often it is used, and how fast the gate operates.
- The operator you choose to install on your gate must be designed for the type and size of your gate and for the frequency with which you use the operator.
- Your gate must be properly installed and must work freely in both directions *before* the automatic operator is installed.
- An automatic operator should be installed on the inside of the property/fence line. Do not install the operator on the public side of the property/fence line.
- Outward swinging gates with automatic operators should not open into a public area.
- Pedestrians should not use a vehicular gate system. Prevent such inappropriate use by installing separate gates for pedestrians.
- The operating controls for an automatic gate must be secured to prevent the unauthorized use of those controls.
- The controls for an automatic gate should be located far enough from the gate so that a user cannot accidentally touch the gate when operating the controls.
- Exposed, reachable pinch points on a gate are potentially hazardous and must be eliminated or guarded.
- It is extremely unsafe to compensate for a damaged gate by over tightening a clutch or increasing hydraulic pressure.
- An automatic gate operator should not be installed on a gate if people can reach or extend their arms or legs through the gate. Such gates should be guarded or screened to prevent such access.

TROUBLESHOOTING

WARNING! Before you do any work on the control panel,
be sure to turn off the main power.

NOTE: Any control panel specific information in the following applies to the 455 D control panel only.

PROBLEM: THE GATE DOES NOT RESPOND TO AN ACTIVATING SIGNAL.

SOLUTION:

You should have at least one operator wired to terminals 1,2 and 3.

Be sure that you have the motor start capacitors wired in terminals 2 and 3, 5 and 6 with the directional leads.

Be sure that the torque/force setting is at the maximum setting of 50 in programming for hydraulic operations.

Verify that the LEDs FSWOP, FSWCL, and the STOP are illuminated. If they are not illuminated, be sure that you have closed circuits in the stop and reversing inputs.

Verify that your activating device works properly. OP_A should illuminate when you signal the gate to open. If OP_A does not illuminate when you signal the gate, then the problem may be in your activating device. Short across terminals 9 and 14. If the short causes the gate to open, then the problem is in the activating device. Repair or replace the device.

PROBLEM: THE GATE DOESN'T OPEN (OR CLOSE) THOUGH THE MOTORS ARE RUNNING.

SOLUTION:

Make sure that the motor is running in the right direction, and make sure the Manual Release mechanism has fully engaged the system.

PROBLEM: THE GATE OPENS BUT DOES NOT CLOSE.

SOLUTION:

Make sure you have selected the desired operating mode.

Verify that the reversing devices are working properly. FSWOP and FSWCL should be illuminated except when a reversing device is triggered. If either does not illuminate, then one of your reversing devices is preventing the gate from responding to your signal.

Check your reversing devices.

If no reversing devices are installed, make sure a circuit is installed between appropriate terminals.

PROBLEM: THE GATE DOES NOT FULLY OPEN (OR CLOSE).

SOLUTION:

Check the operator's open/close time selection. You should set a time that is just longer than the rated speed of your model of operator. For example, because the 415 L LS Operator has a rated opening time of 13 sec, you should set the time at 20 or 25 seconds.

Check to see that there are no obstructions in the path of the gate or that the hinges are not binding.

PROBLEM: THE OPERATOR DOESN'T WORK SMOOTHLY AND THE GATE JERKS AS IT OPENS AND CLOSES.

SOLUTION:

Make sure the Manual Release Mechanism has fully engaged the worm screw operation of the operator.

Make sure that a flexible gate leaf is not the problem. If the gate leaf flexes, then stiffen the gate or use a slower operator.

LIMITED WARRANTY

To the original purchaser only: FAAC International, Inc., warrants, for twenty-four (24) months from the date of invoice, the gate operator systems and other related systems and equipment manufactured by FAAC S.p.A. and distributed by FAAC International, Inc., to be free from defects in material and workmanship under normal use and service for which it was intended *provided* it has been properly installed and operated. FAAC International, Inc.'s obligations under this warranty shall be limited to the repair or exchange of any part of parts manufactured by FAAC S.p.A. and distributed by FAAC International, Inc. Defective products must be returned to FAAC International, Inc., freight prepaid by purchaser, within the warranty period. Items returned will be repaired or replaced, at FAAC International, Inc.'s option, upon an examination of the product by FAAC International, Inc., which discloses, to the satisfaction of FAAC International, Inc., that the item is defective. FAAC International, Inc. will return the warranted item freight prepaid. The products manufactured by FAAC S.p.A. and distributed by FAAC International, Inc., are not warranted to meet the specific requirements, if any, of safety codes of any particular state, municipality, or other jurisdiction, and neither FAAC S.p.A. or FAAC International, Inc., assume any risk or liability whatsoever resulting from the use thereof, whether used singly or in combination with other machines or apparatus.

Any products and parts not manufactured by FAAC S.p.A. and distributed by FAAC International, Inc., will carry only the warranty, if any, of the manufacturer. This warranty shall not apply to any products or parts thereof which have been repaired or altered, without FAAC International, Inc.'s written consent, outside of FAAC International, Inc.'s workshop, or altered in any way so as, in the judgment of FAAC International, Inc., to affect adversely the stability or reliability of the product(s) or has been subject to misuse, negligence, or accident, or has not been operated in accordance with FAAC International, Inc.'s or FAAC S.p.A.'s instructions or has

been operated under conditions more severe than, or otherwise exceeding, those set forth in the specifications for such product(s). Neither FAAC S.p.A. or FAAC International, Inc., shall be liable for any loss or damage whatsoever resulting, directly or indirectly, from the use or loss of use of the product(s). Without limiting the foregoing, this exclusion from liability embraces a purchaser's expenses for downtime or for making up downtime, damages for which the purchaser may be liable to other persons, damages to property, and injury to or death of any persons. Neither FAAC S.p.A. or FAAC International, Inc., assumes nor authorizes any person to assume for them any other liability in connection with the sale or use of the products of FAAC S.p.A. or FAAC International, Inc. The warranty hereinabove set forth shall not be deemed to cover maintenance parts, including, but not limited to, hydraulic oil, filters, or the like. No agreement to replace or repair shall constitute an admission by FAAC S.p.A. or FAAC International, Inc., of any legal responsibility to effect such replacement, to make such repair, or otherwise. This limited warranty extends only to wholesale customers who buy directly through FAAC International, Inc.'s normal distribution channels. FAAC International, Inc., does not warrant its products to end consumers. Consumers must inquire from their selling dealer as to the nature and extent of that dealer's warranty, if any.

This warranty is expressly in lieu of all other warranties expressed or implied including the warranties of merchantability and fitness for use. This warranty shall not apply to products or any part thereof which have been subject to accident, negligence, alteration, abuse, or misuse or if damage was due to improper installation or use of improper power source, or if damage was caused by fire, flood, lightning, electrical power surge, explosion, wind storm, hail, aircraft or vehicles, vandalism, riot or civil commotion, or acts of God.

FAAC International, Inc.
303 Lexington Avenue
Cheyenne, WY 82007
www.faacusa.com